

**Perlick® GLASS FROSTERS**



JOB	
AREA	
ITEM NO.	
MODEL NO.	

MODELS
FR24RT-3
FR36RT-3
FR48RT-3
FR60RT-3



FR24RT-3



FR36RT-3



FR48RT-3

**KEY PRODUCT FEATURES AND BENEFITS**

- Heavy Duty Construction – Stainless steel interior & top
- 2" Foamed-in-place insulation provides energy savings using Ecomate™, a blowing agent that has zero-ozone depletion and zero global warming potential
- Unique door frame heater eliminates condensation build up on door
- Stainless steel interior with choice of all stainless exterior, stainless front and sides with galvanized back, or black vinyl-coated exterior
- Heavy gauge dent resistant doors

**Quick Features:**

- Controller adjustable from -10°F - 10°F; Factory set at 0°F
- Manual 6-hour defrost system prevents interior ice buildup
- Floor racks standard; shelving must be ordered separately if needed (2 shelves recommended)
- Optional third shelf for 3, 4 and 5 foot models adds 25% more glass storage
- Ultra quiet, high-efficiency, R290 refrigeration system
- Plug-in installation, no condensate plumbing required
- 1 Year Parts and Labor Warranty, 5 Year Compressor Warranty



**GLASS FROSTERS**



**Size and Specifications**

MODEL NUMBERS		FR24RT-3	FR36RT-3	FR48RT-3	FR60RT-3
EXTERIOR CABINET DIMENSIONS	Length - in. (mm)	24 (610)	36 (914)	48 (1219)	60 (1524)
	Depth - in. (mm)	24 (610)	24 (610)	24 (610)	24 (610)
	Height - in. (mm)	34-1/8 (866)	34-1/8 (866)	34-1/8 (866)	34-1/8 (866)
INTERNAL NET VOLUME - cubic ft. (liters)		4.2 (118)	8.6 (242)	12.5 (353)	16.3 (462)
PLATE CAPACITY *		135 Plates	215 Plates	300 Plates	400 Plates
GLASS CAPACITY *		90 Glasses	142 Glasses	214 Glasses	286 Glasses
W/ OPTIONAL THIRD SHELF		N/A	172 Glasses	273 Glasses	363 Glasses
SHIPPING WEIGHT LBS. (KG.)		190 (86)	245 (111)	300 (136)	353 (160)
CABINET CONSTRUCTION (INTERIOR)		All models have stainless steel walls and floor.			
CABINET CONSTRUCTION (EXTERIOR)		Choice of black, stainless steel and all stainless. <b>Black Option:</b> Front and ends are black vinyl coated steel, back and bottom are galvanized. <b>Stainless Steel Option:</b> Front and ends are stainless steel, back and bottom are galvanized. <b>All Stainless Option:</b> Front, ends, back and bottom are all stainless steel.			
DOORS AND HARDWARE		Sliding style open. Stainless steel top and bottom pans. Die cast handle			
PLUMBING		No drain required. Condensate evaporates automatically.			
INSULATION		2 inch foamed-in-place, Ecomate® polyurethane insulation.			
VENTILATION		FR24 model is front vented, all other models require 2" clearance from wall on either left end or back of cabinet for proper air flow.			
TEMPERATURE SPECIFICATIONS	Default Temperature Setpoint: Standard Temp Models - °F [°C]	0 [-17.75]			
	Adjustable Setpoint Range: Standard Temp Models - °F [°C]	(-) 10 to (+)10 [-23.3 to -12.2]			
ELECTRICAL SPECIFICATIONS	Supply	120 VAC/60 Hz/1 Ph			
	Running Load Amps	3.8	3.8	3.8	3.8
	Power Cord	6-foot length with NEMA 5-15 plug.			
	Thermostat	NSF Listed electronic control.			
	Automatic Defrost	Automatic electric defrost every 4 hours for approximately 20 minutes.			
	Manual Defrost	Push button defrost system, manually initiated at the end of each day. Automatically terminates after six hours.			
REFRIGERATION SPECIFICATIONS	Condensing Unit	Hermetic condensing unit pulls out for service and cleaning.			
	Expansion Device	Capillary Tube			
	Refrigerant	R290			
	Refrigerant Charge (g)	80	100	100	115
	Compressor H.P.	1/4	1/4	1/4	1/4
	Total Heat of Rejection At 75°F ambient (BTU/h)	1530	1625	1625	1670
OPTIONAL ACCESSORIES		Flat shelving • Divider shelving • Roller basket shelving Set of 4 Adjustable legs (Multiple sizes available) Set of 4 Casters w/ brakes (Multiple sizes available) • 2; 3; 4; and 5' Bottle Rail (field Installed)			

\* Capacity based on use of 3" diameter glass and 9-1/2" diameter X 1/2" thick plate.

# This product is evaluated by NSF for the chilling of glassware and plates. This product is not intended for the storage of food products.

**California Prop 65 Notice:**



**WARNING:** The materials used in this product may contain chemicals known to the State of California to cause cancer and birth defects or other reproductive harm, For more information go to [www.P65Warnings.ca.gov](http://www.P65Warnings.ca.gov).

Form No. Z2379  
Rev. 01 08 25



**GLASS FROSTERS**

**24" CABINET**

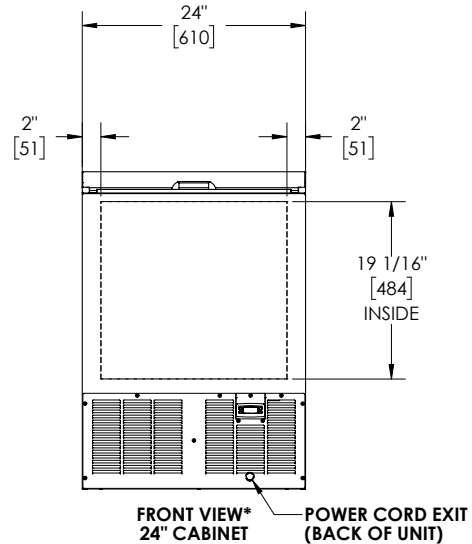
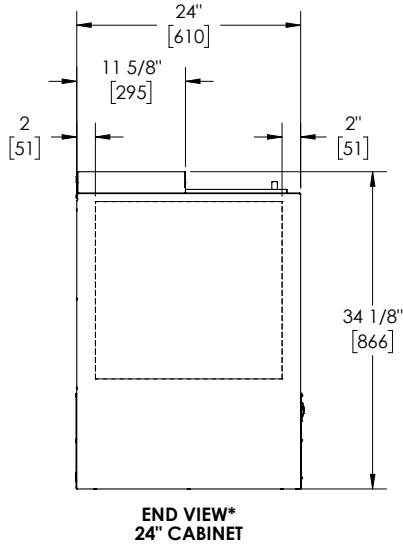

**36", 48", 60" CABINET**

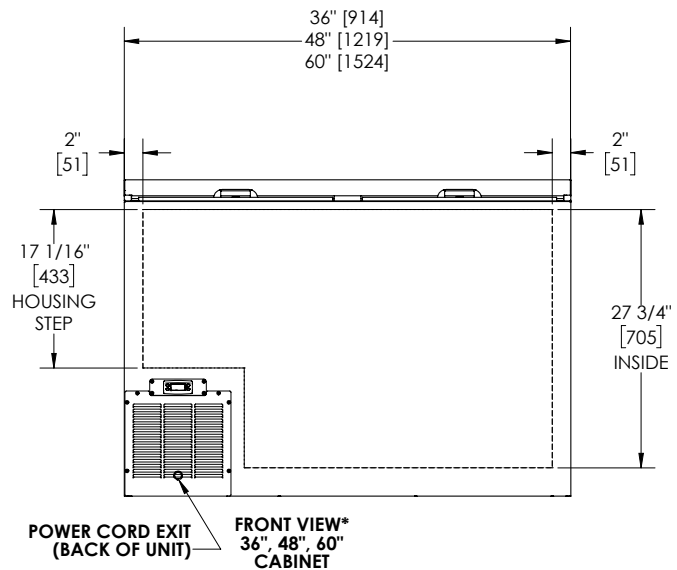
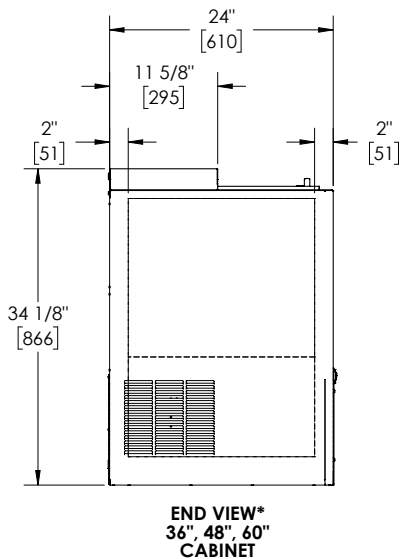

**California Prop 65 Notice:**



**WARNING:** The materials used in this product may contain chemicals known to the State of California to cause cancer and birth defects or other reproductive harm, For more information go to [www.P65Warnings.ca.gov](http://www.P65Warnings.ca.gov).

Form No. Z2379  
Rev. 01 08 25