

BACK VIEW

NOTE: THE 1/2" X 1-3/4" SECTION CAN BE ADDED AS SEPARATE MITERED PIECES.

OPTIONAL GLUE JOINT FOR MULTIPLE PIECE CONSTRUCTION.

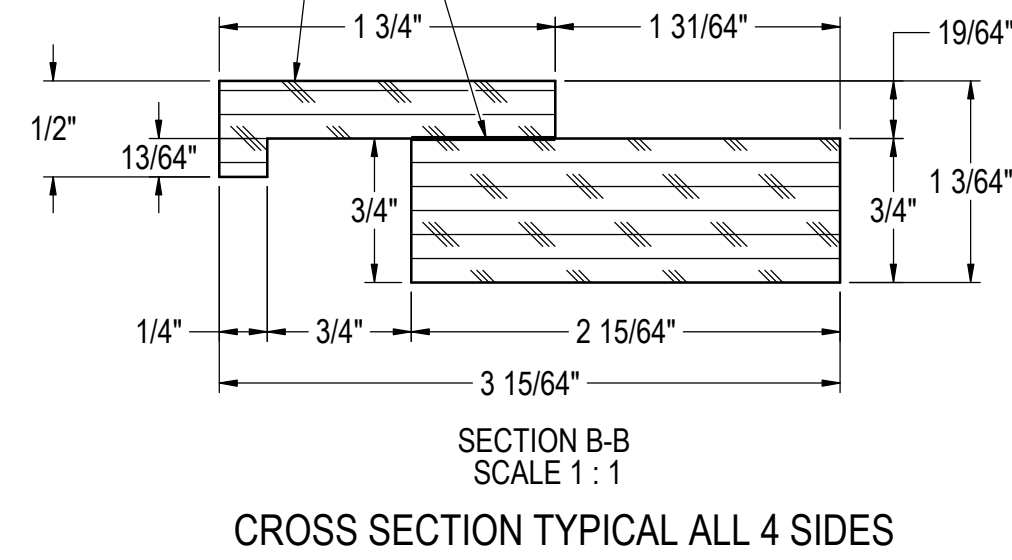
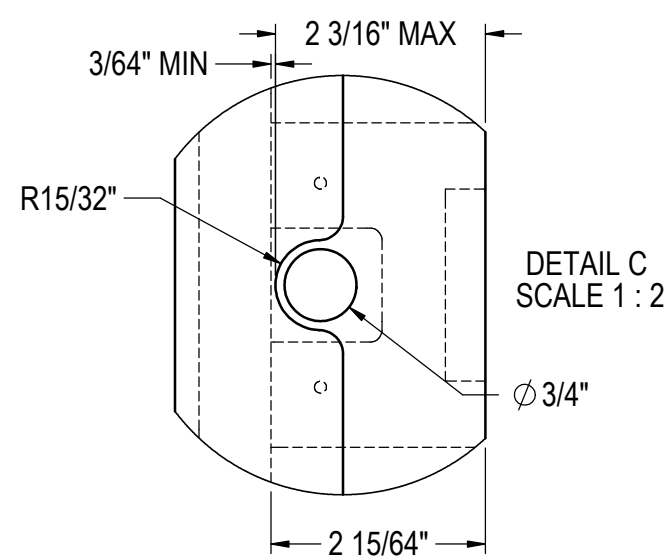

NOTE: VALID FOR ANY ORDERS ENTER ON OR AFTER JAN. 1, 2016

RELEASE FOR PRODUCTION		
A	11/10/2015	JMP
REVISIONS		

MATERIAL: WOOD	SIGNATURES	DATE	Perlick Corporation Milwaukee, Wisconsin	
	DESIGNED JMP	11/10/2015		
QTY.:	DRAWN JMP	11/10/2015	TITLE: GLASS DOOR WOOD OVERLAY 24" DOOR, HD & HB CABINETS	
	UNLESS OTHERWISE SPECIFIED: DIMENSIONS ARE IN INCHES TOLERANCES: X = ±.1, .XX = ±.03, .XXX = ±.015, ANGULAR: ±1.5°, FRACTIONS: ±1/64 BREAK SHARP EDGES - .015 X 45° RADIUS SHARP FILLETS - .015 TO .031 HOLES: Ø.0135 THRU Ø.125: ±.004 Ø.1260 THRU Ø.250: ±.005 Ø.2510 THRU Ø.500: ±.006 Ø.5010 THRU Ø.750: ±.008 Ø.7510 THRU Ø.1.000: ±.010 Ø.1.001 & UP: ±.012		REFERENCE: PART NO. 68135A-7	
FINISH: CUSTOM			DWG NO. 68135A	PURCHASE REC.:
			SCALE = 1:8	SHEET 7 OF 9

THIS DOCUMENT / PUBLICATION / SOFTWARE / DRAWING CONTAINS PROPRIETARY INFORMATION WHICH IS THE PROPERTY OF THE PERLICK CORPORATION. IT MAY NOT BE REPRODUCED OR TRANSMITTED IN ANY FORM, ELECTRONIC OR MECHANICAL, INCLUDING PHOTOCOPYING, RECORDING, OR USED IN ANY INFORMATION STORAGE, TRANSMISSION, OR RETRIEVAL SYSTEM, WITHOUT WRITTEN PERMISSION FROM THE PERLICK CORPORATION. COPYRIGHT 2001 PERLICK CORPORATION. ALL RIGHTS RESERVED.

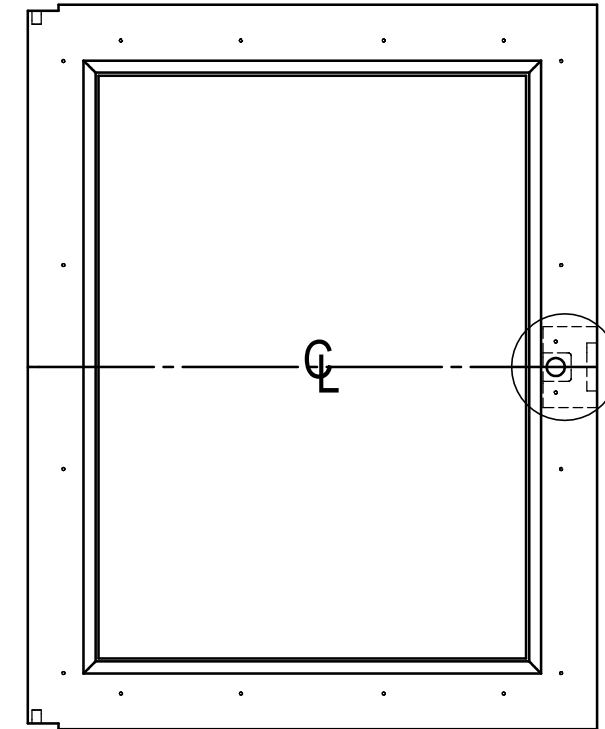
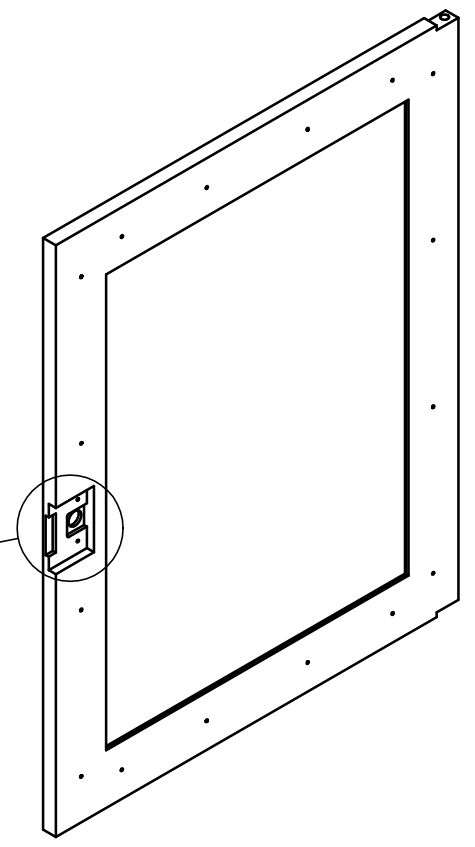
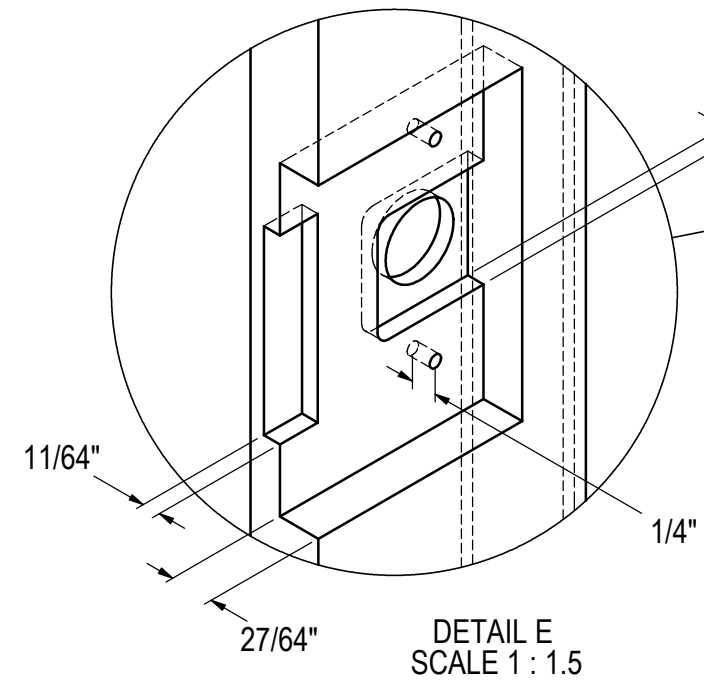
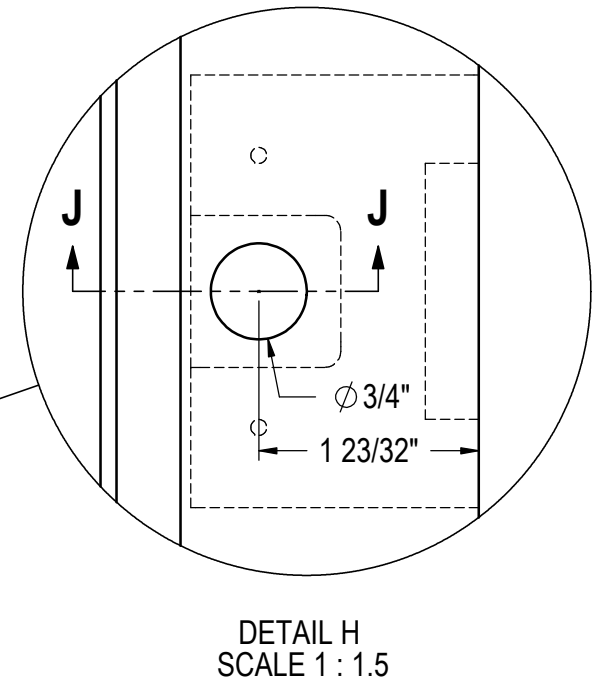
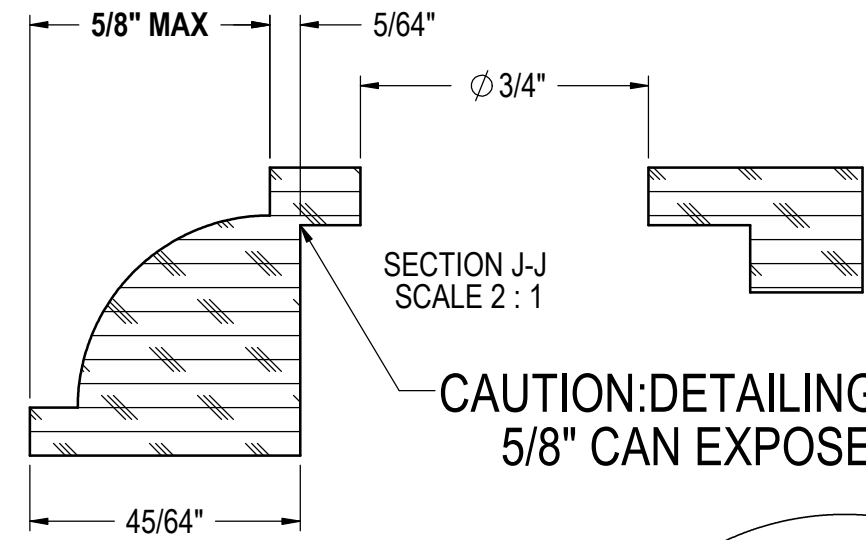
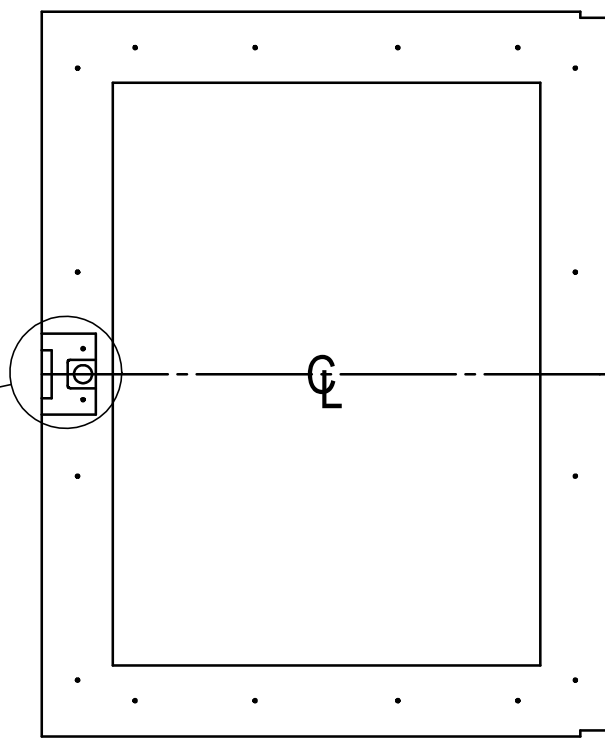
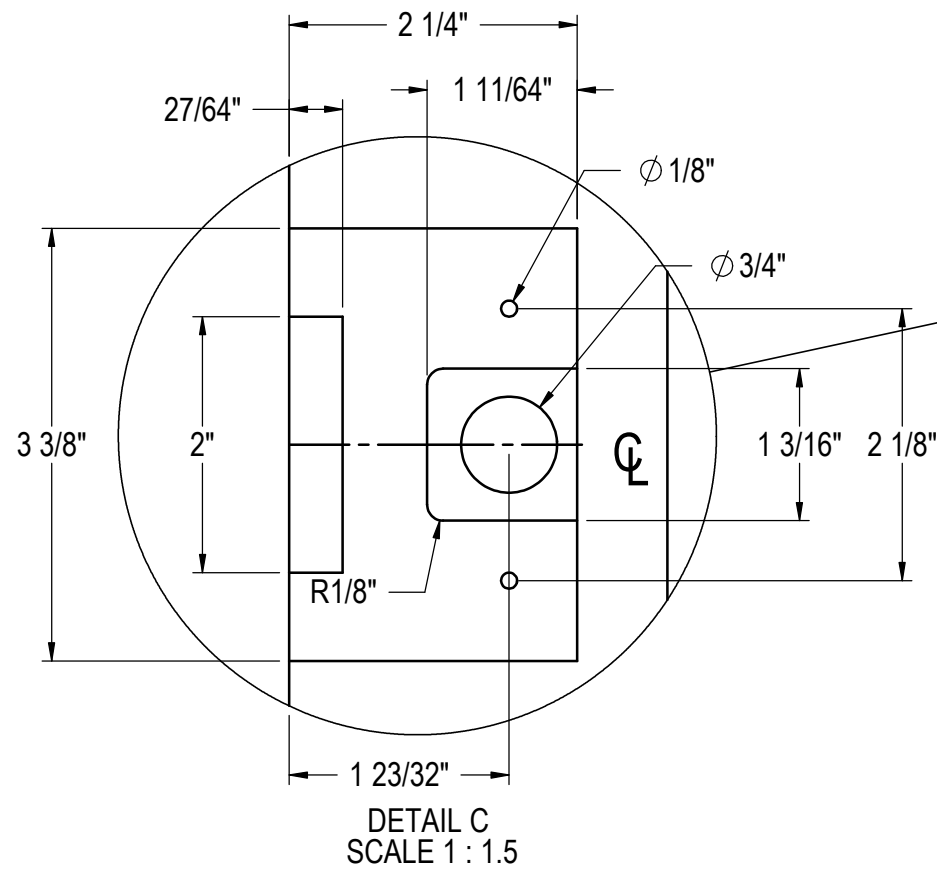

**NOTE: VALID FOR ANY ORDERS
ENTER ON OR AFTER JAN. 1, 2016**

RELEASE FOR PRODUCTION		
A	11/10/2015	JMP
REVISIONS		

MATERIAL: WOOD - CUSTOMER DISCRETION	SIGNATURES	DATE	Perlick Corporation Milwaukee, Wisconsin	
	DESIGNED JMP	11/10/2015		
QTY.:	DRAWN JMP	11/10/2015	TITLE: WOOD OVERLAY, GLASS DOOR HP, HC, & BACK BAR DOORS w/LOCKS	
	UNLESS OTHERWISE SPECIFIED: DIMENSIONS ARE IN INCHES TOLERANCES: X = ±.1, .XX = ±.03, .XXX = ±.015, ANGULAR: ±1.5°, FRACTIONS: ±1/64 BREAK SHARP EDGES - .015 X 45° RADIUS SHARP FILLETS - .015 TO .031		REFERENCE:	
FINISH: CUSTOM	HOLES: Ø .0135 THRU Ø .125: ±.004 Ø .1260 THRU Ø .250: ±.005 Ø .2510 THRU Ø .500: ±.006 Ø .5010 THRU Ø .750: ±.008 Ø .7510 THRU Ø 1.000: ±.010 Ø 1.001 & UP: ±.012		PART NO.	DWG NO.
			PURCHASE REC.:	SCALE = 1:8
			88135A	
			SHEET 9 OF 9	

THIS DOCUMENT / PUBLICATION / SOFTWARE / DRAWING CONTAINS PROPRIETARY INFORMATION WHICH IS THE PROPERTY OF THE PERLICK CORPORATION. IT MAY NOT BE REPRODUCED OR TRANSMITTED IN ANY FORM, ELECTRONIC OR MECHANICAL, INCLUDING PHOTOCOPYING, RECORDING, OR USED IN ANY INFORMATION STORAGE, TRANSMISSION, OR RETRIEVAL SYSTEM, WITHOUT WRITTEN PERMISSION FROM THE PERLICK CORPORATION. COPYRIGHT 2001 PERLICK CORPORATION. ALL RIGHTS RESERVED.