



Self-Contained Cubelet Ice Maker

INSTRUCTION MANUAL



PERLICK RESIDENTIAL UNDERCOUNTER ICE MAKER MODELS

HP15CU-IL(-IR)(-2) - 15" Signature Series Cubelet Ice Maker

HA15CU-IL(-IR)(-2) - 15" ADA Compliant Cubelet Ice Maker



CONTENTS

- Important Safety Information 3
- I. Specifications 5
 - A. Construction 5
 - B. Electrical and Refrigerant Data 7
 - C. Dimensions/Connections 7
 - 1. HP15CU-1L(-1R) 8
 - 2. HP15CU-2 9
 - 3. HA15CU-1L(-1R) 10
 - 4. HA15CU-2 11
- II. Installation Instructions 12
 - A. Checks Before Installation 12
 - B. Location 12
 - 1. General 12
 - 2. Built-In Installation Site 13
 - C. Door 14
 - 1. HP15CU-2, HA15CU-2 14
 - D. Setup 22
 - E. Electrical Connection 23
 - F. Water Supply and Drain Connections 24
 - G. Final Checklist 27
 - 1. Pre-Startup 27
 - 2. Post-Startup 27
- III. Operating Instructions 28
 - A. Important Notes About Usage 28
 - B. Startup 30
- IV. Maintenance 32
 - A. Maintenance Schedule 33
 - B. Cleaning and Sanitizing Instructions 34
 - C. Storage Bin Drain 35
 - D. Drain Pump 37
 - E. Condenser 37
- V. Preparing the Appliance for Periods of Non-Use 38
- VI. Disposal 39

INTRODUCTION

Congratulations on your purchase of a Perlick Residential undercounter appliance. This manual has been prepared to assist you in the installation of your undercounter ice maker.

We dedicate considerable time to ensure that our appliances provide the highest level of customer satisfaction. We thank you for selecting Perlick products for your home and assure you of our continuing interest in your satisfaction.

WARRANTY REGISTRATION

To register your Perlick appliance, visit our website at www.perlick.com/RegisterMyPerlick and fill out the form. Once completed, click on the 'Submit Warranty Registration'. Be sure to register your appliance immediately upon installation to receive the warranty from installation date instead of shipment date. If left blank, the date will revert back to shipment date.

 **WARNING: California Prop 65 Notice**
These appliances may expose you to chemicals including Chromium, which are known to the state of California to cause cancer and birth defects or other reproductive harm. For more information on whether a product in this list contains these chemicals, please refer to the specific product page at perlick.com. Or to find out more about **Prop 65**, go to P65Warnings.ca.gov.

IMPORTANT

This manual should be read carefully before the appliance is installed and operated. Read the warnings and guidelines contained in this manual carefully as they provide essential information for the continued safe use and maintenance of the appliance. Retain this manual for any further reference that may be necessary.

SAFETY CONSIDERATIONS

PLEASE READ all instructions completely before attempting to install or operate the unit. Take particular note of the **DANGER, WARNING** and **CAUTION:** information in this manual is important for the safe and efficient installation, operation and care of your Perlick unit.

IMPORTANT!

Read and understand all information in this manual before attempting the installation. All plumbing and electrical work must be performed by a qualified technician and conform to all applicable state and local codes.

⚠ DANGER Indicates a hazard that **WILL** result in serious injury or death if precautions are not followed.

⚠ WARNING Indicates a hazard that **MAY** cause serious injury or death if precautions are not followed.

⚠ CAUTION Indicates a hazard where minor or moderate injury may occur if precautions are not followed.

NOTICE Indicates that property or appliance damage may occur if warnings or instructions are not followed.

⚠ WARNING

This icemaker should be destined only to the use for which it has been expressly conceived. Any other use should be considered improper and therefore dangerous. The manufacturer cannot be held responsible for injury or damage resulting from improper, incorrect, and unreasonable use. Failure to install, operate, and maintain the icemaker in accordance with this manual will adversely affect safety, performance, component life, and warranty coverage and may result in costly water damage.

To reduce the risk of death, electric shock, serious injury, or fire, follow basic precautions including the following:

- Only qualified service technicians should install and service this icemaker.
- This icemaker must be installed in accordance with applicable national, state, and local codes and regulations.
- This icemaker requires an independent power supply of proper capacity. See the nameplate for electrical specifications. Failure to use an independent power supply of proper capacity can result in a tripped breaker, blown fuse, damage to existing wiring, or component failure. This could lead to heat generation or fire.
- **THIS ICEMAKER MUST BE GROUNDED:** This icemaker is equipped with a NEMA 5-15 three-prong grounding plug  to reduce the risk of potential shock hazards. It must be plugged into a properly grounded, independent 3-prong wall outlet. If the outlet is a 2-prong outlet, it is your personal responsibility to have a qualified electrician replace it with a properly grounded, independent 3-prong wall outlet. Do not remove the ground prong from the power cord and do not use an adapter plug.
- Do not use an extension cord.
- To reduce the risk of electric shock, make sure the control switch is in the "OFF" position before plugging in or unplugging the icemaker.
- To reduce the risk of electric shock, do not touch the control switch or plug with damp hands.
- Do not use an icemaker with a damaged power cord. The power cord should not be altered, jerked, bundled, weighed down, pinched, or tangled. Such actions could result in electric shock or fire. To unplug the icemaker, be sure to pull the plug, not the cord, and do not jerk the cord.
- Do not make any alterations to the icemaker. Alterations could result in electric shock, injury, fire, or damage to the icemaker.

⚠ WARNING , Continued

- This appliance is not intended for use by persons (including children) with reduced physical, sensory, or mental capabilities, or lack of experience and knowledge, unless they have been given supervision or instruction concerning use of the appliance by a person responsible for their safety.
- Children should be properly supervised around this appliance.
- Do not climb, stand, or hang on the icemaker or icemaker door or allow children or animals to do so. Serious injury could occur or the icemaker could be damaged.
- Be careful not to pinch fingers when opening and closing the door. Be careful when opening and closing the door when children are in the area.
- Do not use combustible spray or place volatile or flammable substances near the icemaker. They might catch fire.
- Keep the area around the icemaker clean. Dirt, dust, or insects in the icemaker could cause harm to individuals or damage to the icemaker.

NOTICE

- Protect the floor when moving the icemaker to prevent damage to the floor.
- Follow the water supply, drain connection, and maintenance instructions carefully to reduce the risk of costly water damage.
- In areas where water damage is a concern, install in a contained area with a floor drain.
- Install the icemaker in a location that stays above freezing. Normal operating ambient temperature must be within 45°F to 100°F (7°C to 38°C).
- Be aware of water left in the discharge pipe or hose in elevated drain line applications.
- To help ensure that the storage bin drain remains clear, follow the instructions in "IV.C. Storage Bin Drain" once every 3 months or as often as necessary for conditions. If the storage bin drain becomes clogged, water could build up in the bin and overflow, leading to costly water damage.
- Test the drain pump operation every time the icemaker is cleaned and sanitized. See "IV.D. Drain Pump" for details. If the drain pump is not operating properly, water could back up and overflow, leading to costly water damage.
- If water collects in the bin and will not drain, turn off the icemaker and close the water supply line shut-off valve. Call for service.
- Do not leave the icemaker on during extended periods of non-use, extended absences, or in sub-freezing temperatures. To properly prepare the icemaker for these occasions, follow the instructions in "V. Preparing the Icemaker for Periods of Non-Use."
- Keep ventilation openings, in the appliance enclosure or in the built-in structure, clear of obstruction.
- Do not place objects on top of the icemaker.
- The storage bin is for ice use only. Do not store anything else in the storage bin.

I. SPECIFICATIONS

A. Construction

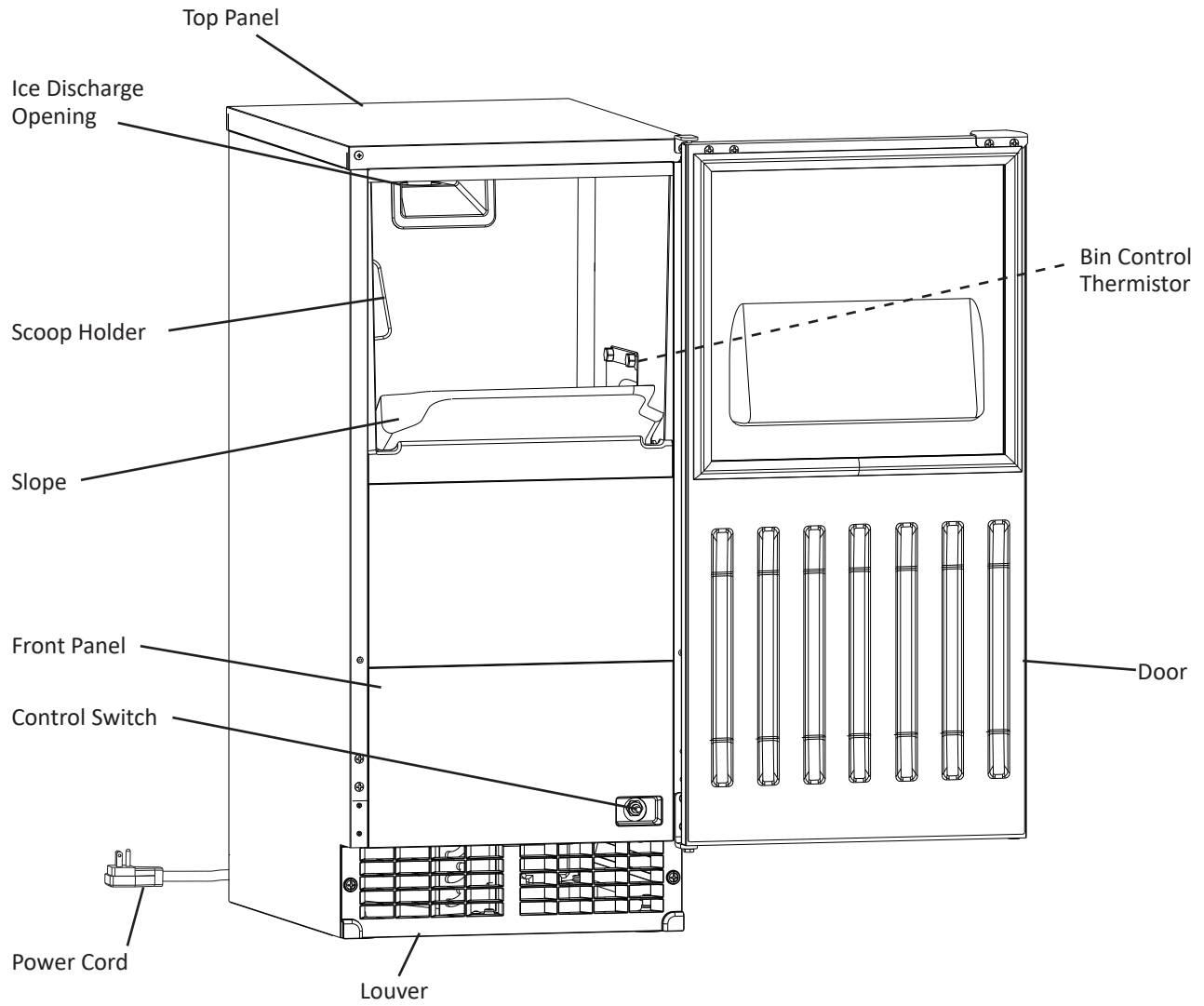



I. SPECIFICATIONS

B. Electrical and Refrigerant Data

The nameplate provides electrical and refrigerant data. The nameplate is located inside the storage bin. For certification marks, see the nameplate.

We reserve the right to make changes in specifications and design without prior notice.

Model Number	HP15CU-1L(-1R) HP15CU-2 HA15CU-1L(-1R) HA15CU-2
AC Supply Voltage	115-120/60/1
Amperes	4.0 AMPS
Design Pressure	HI-240PSI LO-120PSI
Refrigerant	134a 3.92 OZ. (112 g)

I. SPECIFICATIONS

C. Dimensions/Connections

1. HP15CU-1L(-1R)

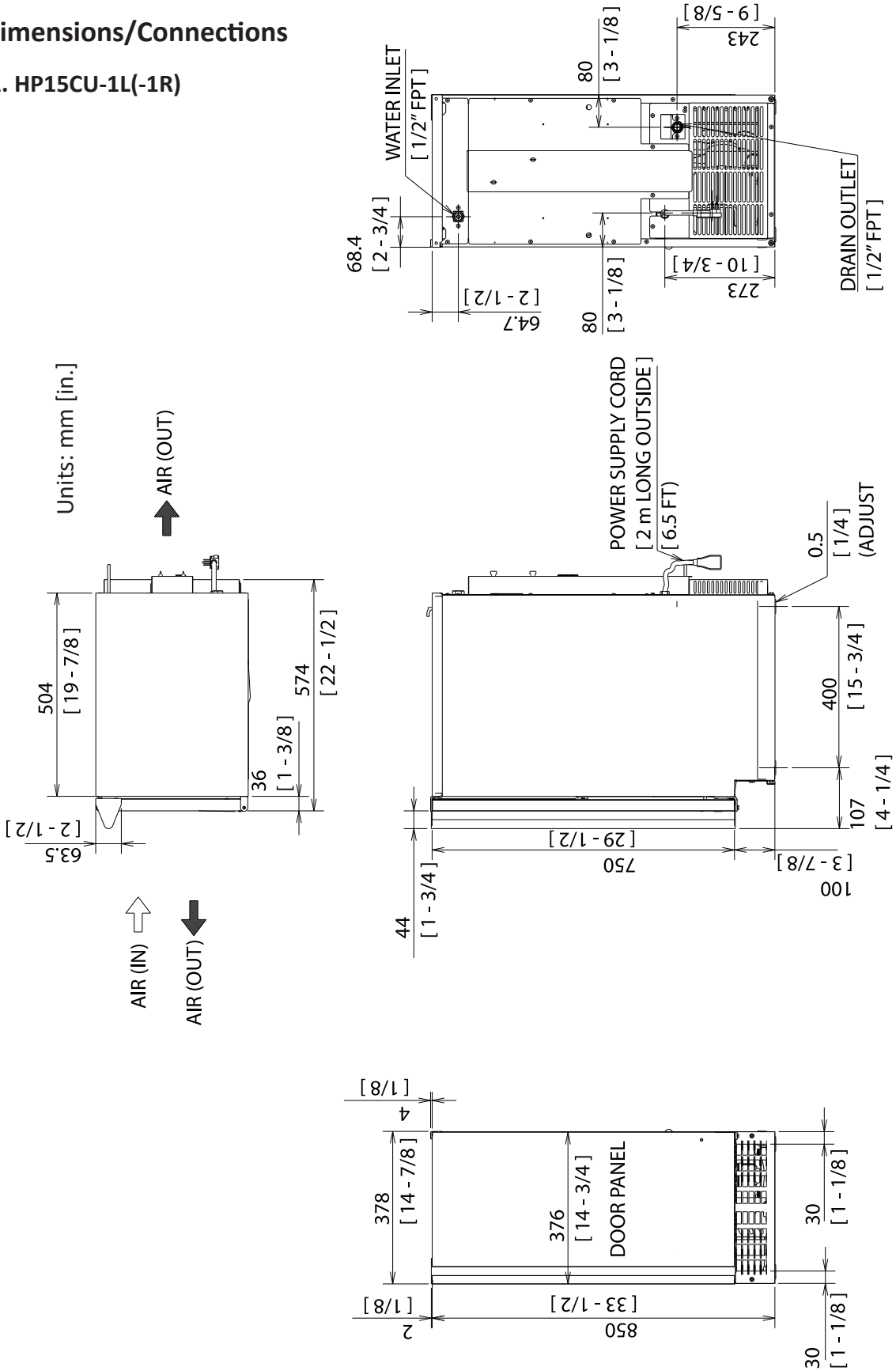

I. SPECIFICATIONS

2. HP15CU-2

Units: mm [in.]

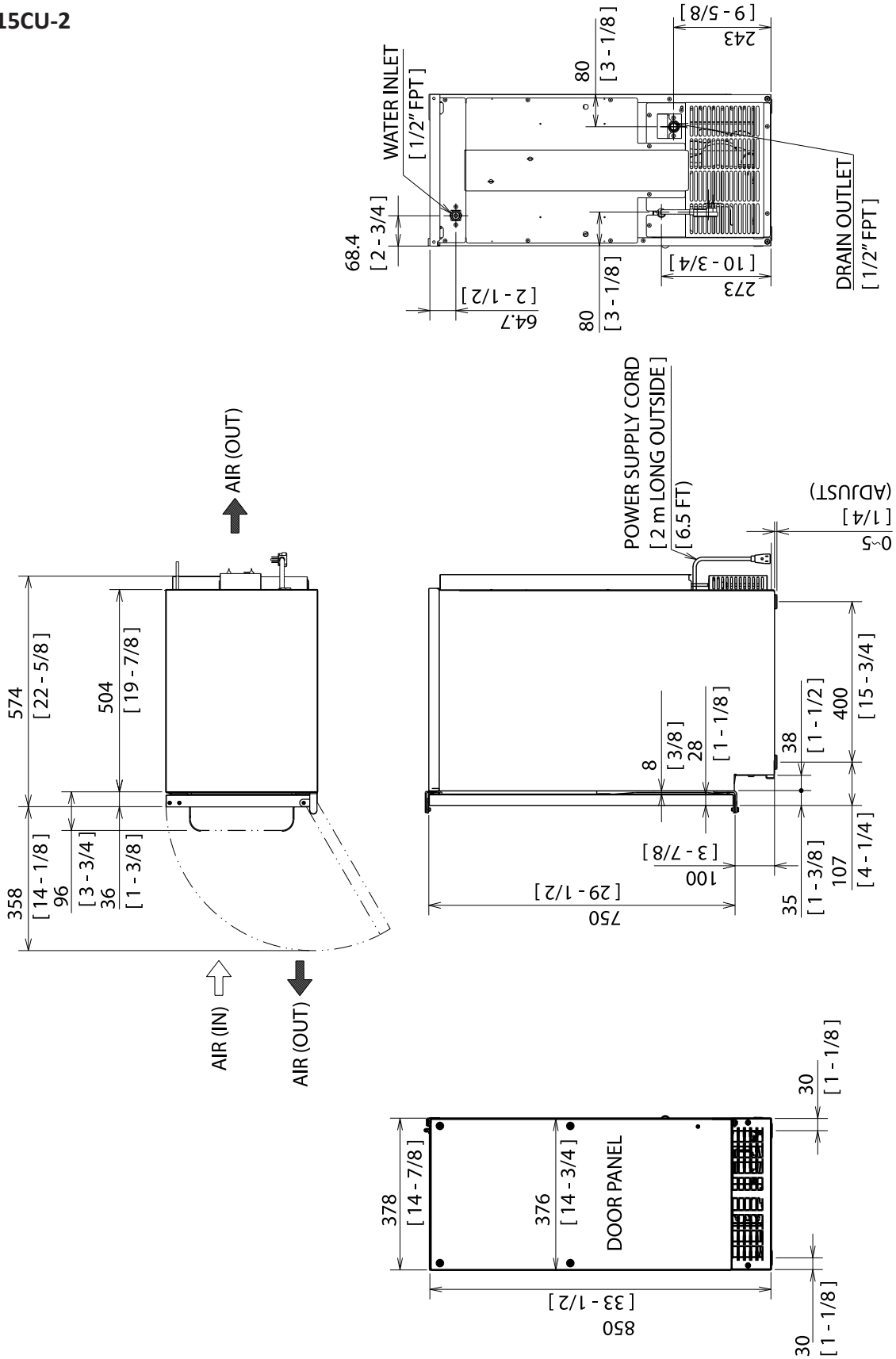

I. SPECIFICATIONS

3. HA15CU-1L(-1R)

Units: mm [in.]

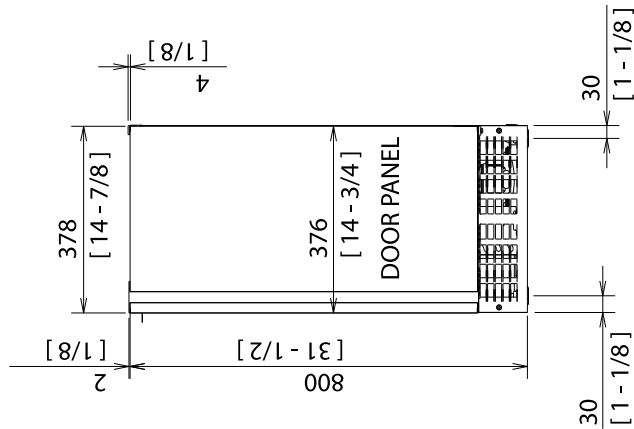
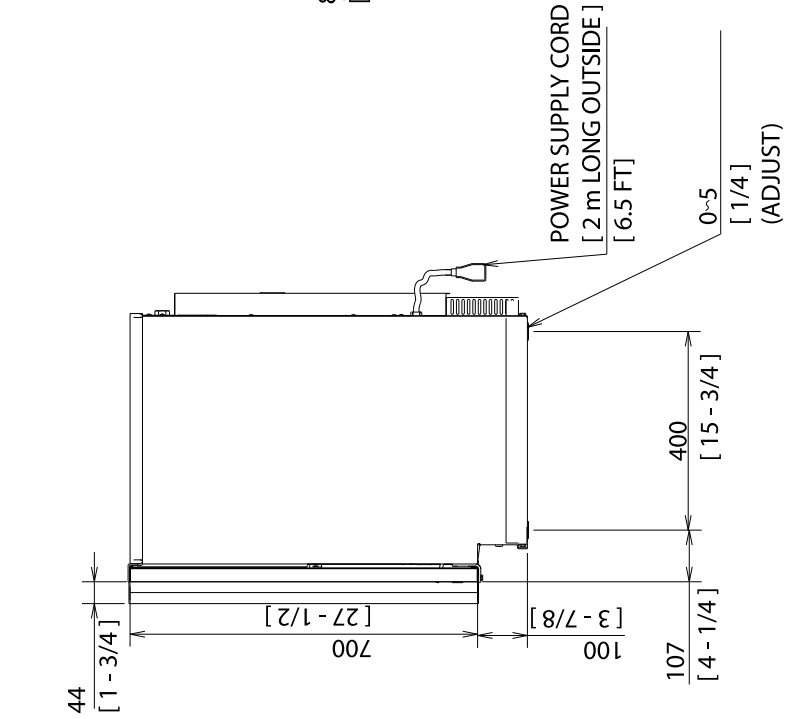
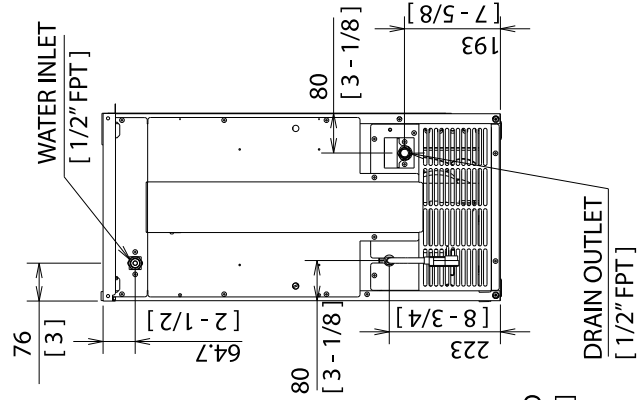
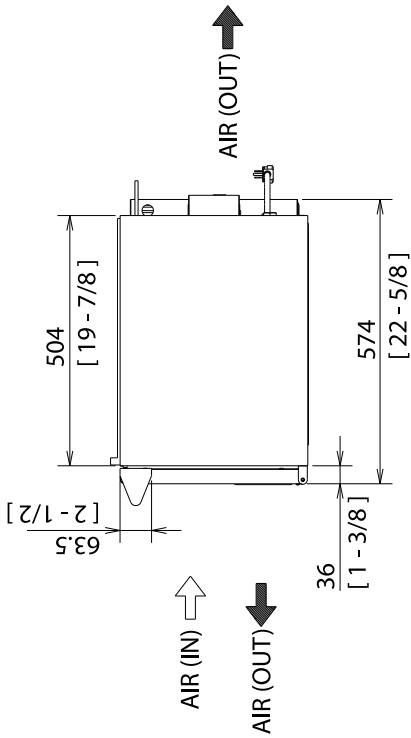

II. INSTALLATION INSTRUCTIONS

⚠ WARNING

- The appliance must be installed in accordance with applicable national, state, and local codes and regulations.
- Failure to install, operate, and maintain the appliance in accordance with this manual will adversely affect safety, performance, component life, and warranty coverage and may result in costly water damage.
- **CHOKING HAZARD:** Ensure all components, fasteners, and thumbscrews are securely in place after installation. Make sure that none have fallen into the storage bin.

A. Checks Before Installation

- Visually inspect the exterior of the shipping container and immediately report any damage to the carrier. Upon opening the container, any concealed damage should also be immediately reported to the carrier.
- Remove the shipping carton, tape, and packing material. If any are left in the appliance, it will not work properly.
- Remove the package containing the accessories.
- Remove the protective plastic film from the panels. If the appliance is exposed to the sun or to heat, remove the film after the appliance cools.
- See the nameplate on the rear panel, and check that your voltage supplied corresponds with the voltage specified on the nameplate.

B. Location

1. General

The appliance is approved for indoor or outdoor use.

NOTICE

- Normal operating ambient temperature must be within 45°F to 100°F (7°C to 38°C); Normal operating water temperature must be within 45°F to 90°F (7°C to 32°C). Operation of the appliance, for extended periods, outside of these normal temperature ranges may affect appliance performance.
- The appliance will not work at sub-freezing temperatures. To prevent damage to the water supply line, drain the appliance if the air temperature is going to go below 32°F (0°C). See "V. Preparing the Appliance for Periods of Non-Use."

- The appliance should not be located next to ovens, grills, or other high heat producing equipment.
- The location must provide a firm and level foundation for the appliance.
- The appliance requires no side or top clearance. But allow enough space at rear for water supply and drain connections and at least 15" (38 cm) clearance at front.
- The appliance must be at floor level on a finished floor even if under a cabinet. In areas where water damage is a concern, install in a contained area with a floor drain.

II. INSTALLATION INSTRUCTIONS
2. Built-In Installation Site
NOTICE

- Do not let the weight of the counter rest on the appliance.
- Do not install the appliance in a corner where the door will interfere with other equipment or where the appliance cannot be pulled out for service.

Installation Space			
Model	Height	Width	Depth
HP15CU-1L(-1R) HP15CU-2	34" (864 mm) minimum	15" (381 mm) minimum	24" (610 mm) minimum
HA15CU-1L(-1R) HA15CU-2	32" (814 mm) minimum		

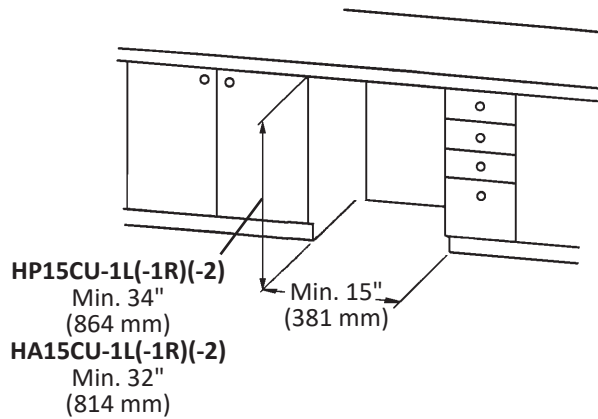
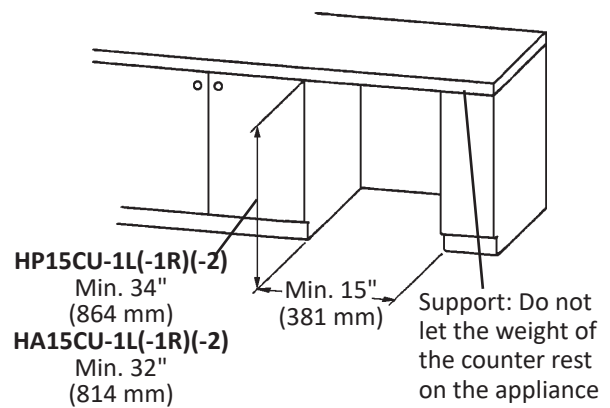
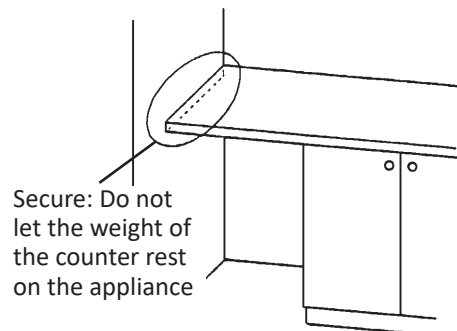
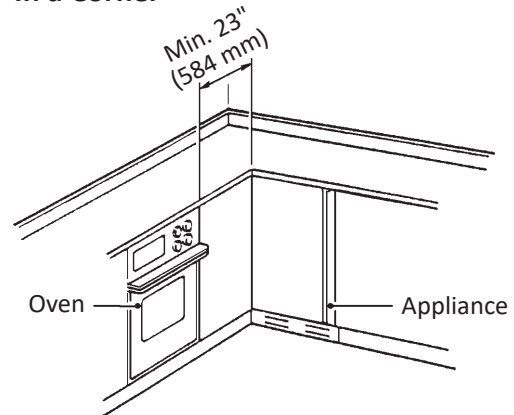
Between Two Cabinets

Between a Cabinet and the End of a Counter

Between a Cabinet and a Wall or Tall Cabinet

In a Corner

II. INSTALLATION INSTRUCTIONS

C. Door

1. HP15CU-2, HA15CU-2

a) Overlay Panel Fabrication and Attachment

IMPORTANT

The overlay panel must be crafted by a professional cabinet maker to ensure quality results.

(1) Parts

Ensure that all parts required for the overlay panel assembly are contained in the accessories bag.

Overlay Panel Parts			
No.	Description	Part Number	Qty.
1	Threaded Wood Insert	4A4004-01	6
2	T2 Screw 4x8 SS	7P32-0408	3
3	Pan Head Screw M4x25 SS	7C12-0425	4
4	Truss Head Screw M4x8 SS	7C32-0408	2
5	Canoe Clip	4A5835-01	2
6	Sheet Metal Bracket	4A3998-01	1

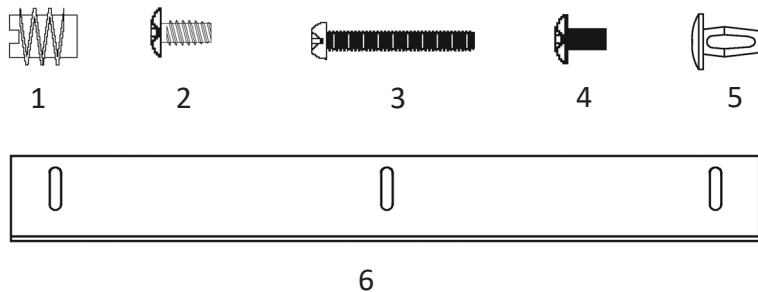

II. INSTALLATION INSTRUCTIONS

(2) Overlay Panel Specification

Use the specification that applies to your appliance (HP15CU-2 or HA15CU-2) and the directions that follow to prepare your overlay panel.

(a) HA15CU-2

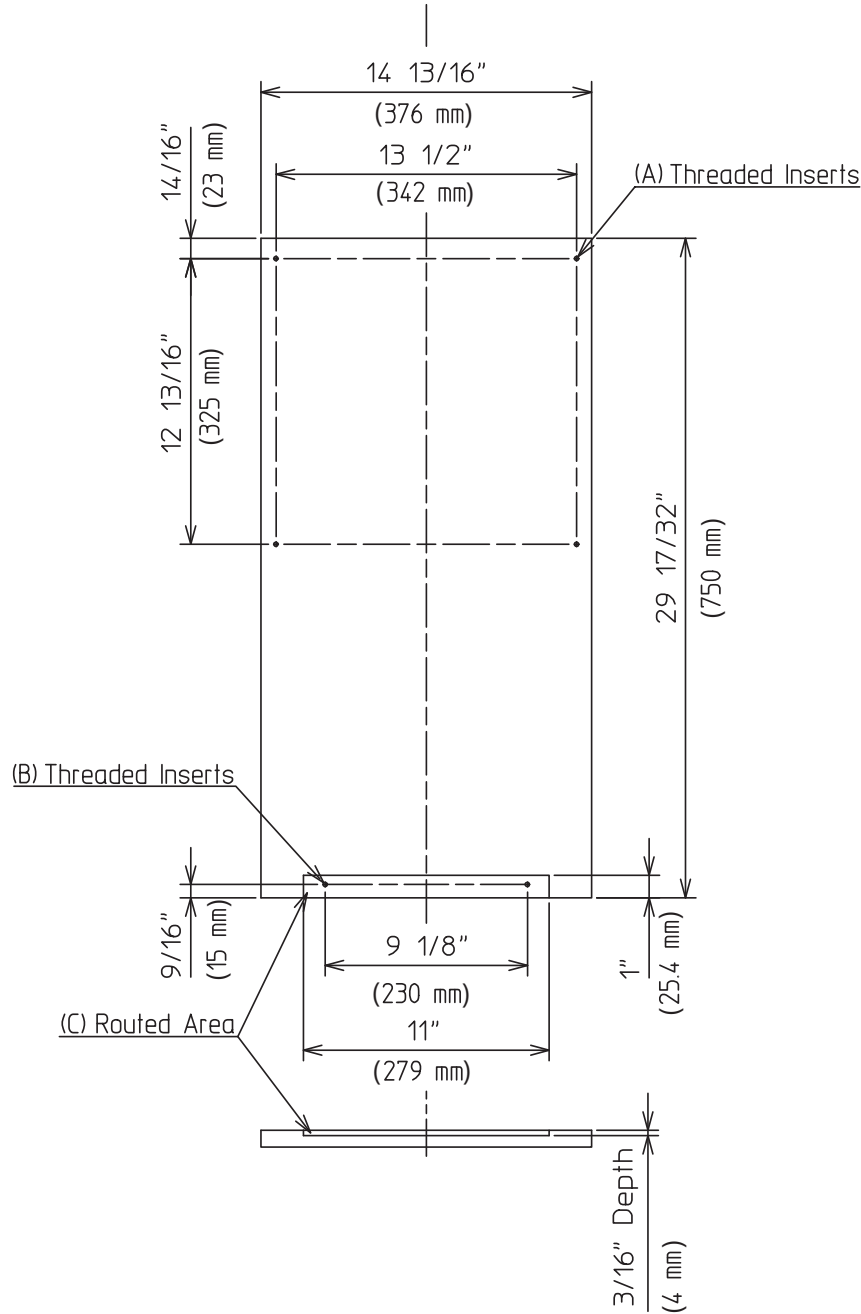

HA15CU-2 Overlay Panel Specification

Overlay Panel Height	29 17/32" (750 mm)
Overlay Panel Width	14 13/16" (376 mm)
Overlay Panel Thickness	5/8" (16 mm) minimum; 3/4" (19 mm) maximum
Overlay Panel and Door Weight (total)	20 lb. (9 kg) maximum

II. INSTALLATION INSTRUCTIONS

(b) HA15CU-2

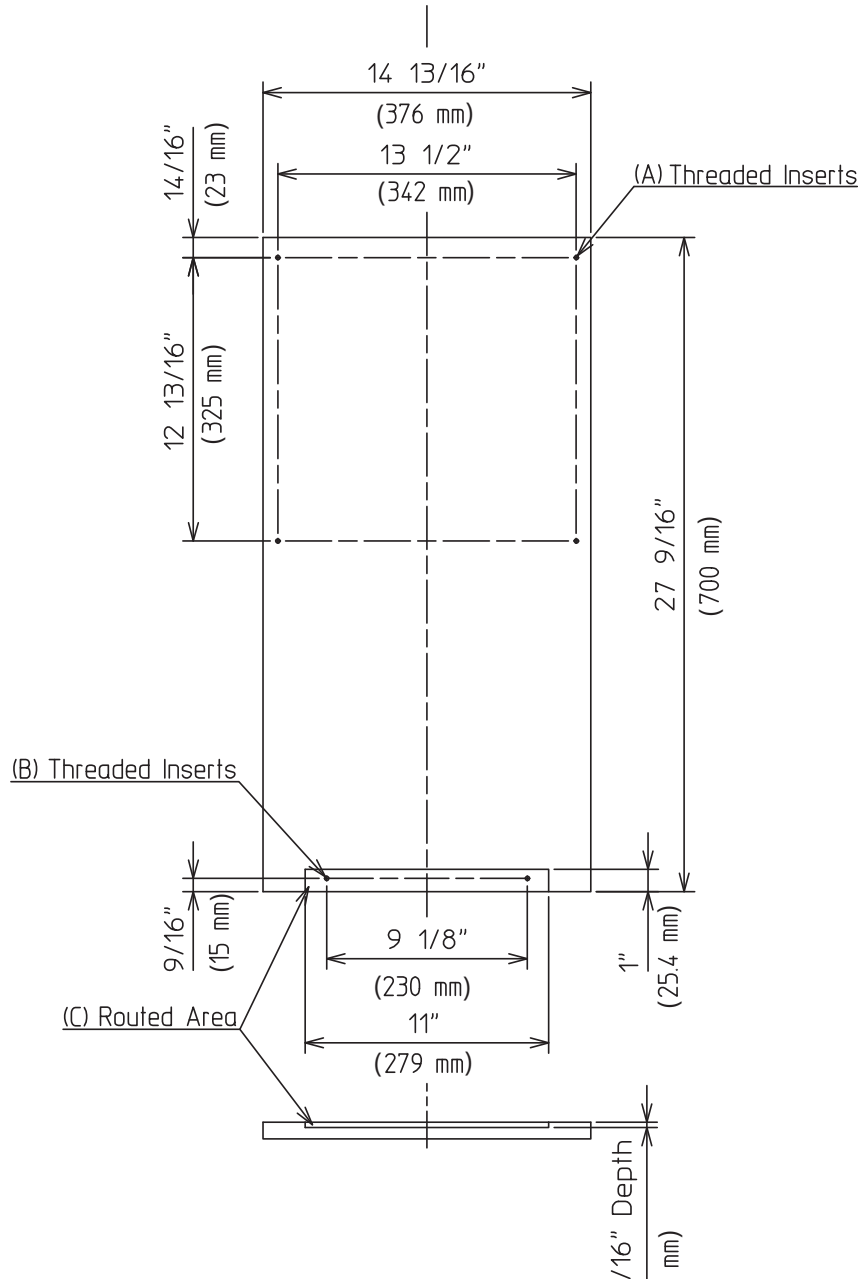

HA15CU-2 Overlay Panel Specification	
Overlay Panel Height	27 9/16" (700 mm)
Overlay Panel Width	14 13/16" (376 mm)
Overlay Panel Thickness	5/8" (16 mm) minimum; 3/4" (19 mm) maximum
Overlay Panel and Door Weight (total)	20 lb. (9 kg) maximum

II. INSTALLATION INSTRUCTIONS

(3) Fabrication of Overlay Panel

Fabricate the overlay panel as outlined in the specification on the previous page and the instructions below.

- 1) Route a channel at the bottom of the overlay panel to the proper dimensions. See "(C) Routed Area" in the specification diagram and Fig. 8.
- 2) Drill six 1/4" diameter (hardwood may require slightly larger diameter) holes 3/8" (10 mm) deep in the locations designated. **NOTICE! Use care when drilling holes for mounting hardware. All drilled holes must be straight and drilled to the correct diameter and depth.** See "(A) Threaded Inserts" and "(B) Threaded Inserts" in the specification diagram and Fig. 9.

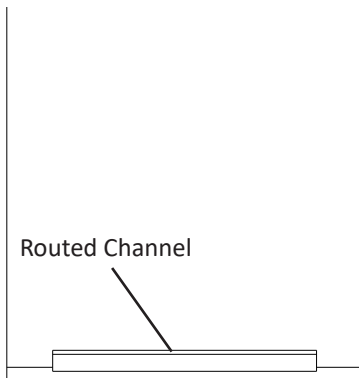

Fig. 8

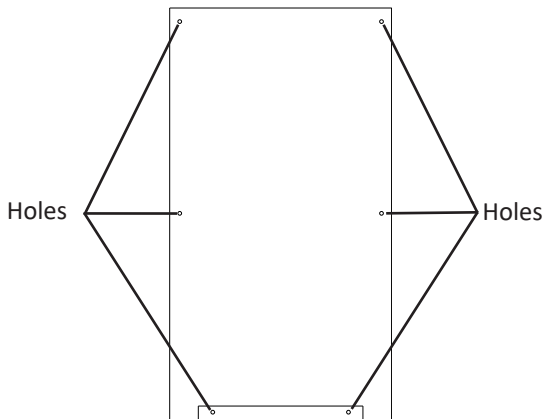

Fig. 9

- 3) Screw the 6 threaded wood inserts into the 1/4" holes drilled in the previous step. Make sure that the inserts are threaded straight and that the tops of the inserts are flush to the overlay panel surface. Otherwise, the overlay panel cannot be properly fastened to the door.
- 4) Mount the door handle hardware. Perlick recommends that the door handle hardware be mounted on the edge opposite of the door hinge side (optional hinge reversal is covered in step 6). Countersunk screw heads are required to ensure that the hardware fasteners do not interfere with the overlay panel fitting flush with the door.
- 5) While maintaining a hold on the door, remove the hinge stop pin from hinge (B). Pull out the bottom of the door slightly and gently remove the door from hinge (A). See Fig. 10. If you are leaving the door right-hinged, skip to step 7. If you would like to reverse the door hinges, proceed to step 6.

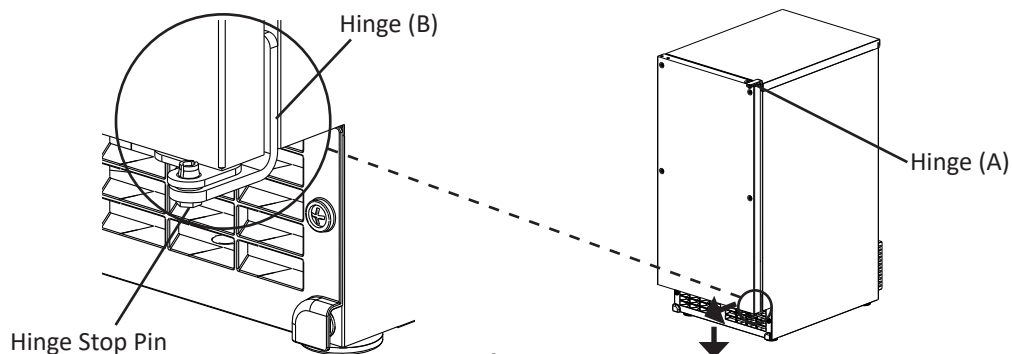

Fig. 10

II. INSTALLATION INSTRUCTIONS

- 6) If you would like to reverse the door hinges, do the following:
- a) Contact your local distributor to purchase a Perlick hinge kit. The kit contains "hinge (A)-left."
 - b) Remove the 2 bolts securing the top panel, then lift it off. See Fig. 11.
 - c) Remove hinge (A)-right and the bracket from the right side of the appliance. Set aside hinge (A)-right; it is not needed. Remove the top brace from the left side. Fasten hinge (A)-left and the bracket to the left side and the top brace to the right side. See Fig. 12.
Note: When on the proper side, the gasket notch for hinge (A) is to the inside.

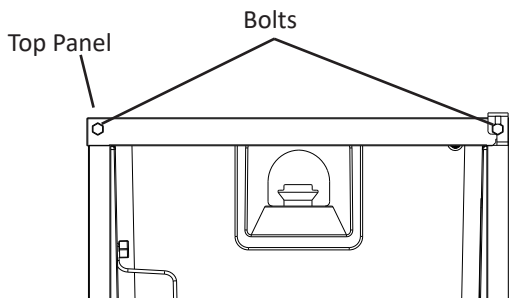

Fig. 11

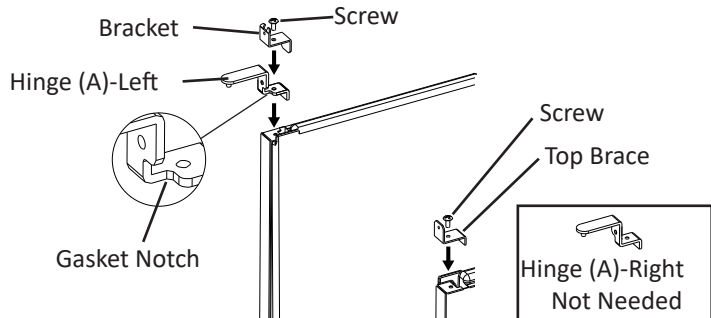

Fig. 12

- d) Remove hinge (B) from the right side of the appliance and the 2 filler screws from the left side. Attach the 2 filler screws to the right side and attach hinge (B) to the left side. See Fig. 13.
- e) Rotate the top panel 180° from its previous position. This brings the notch that was previously in the right rear to the left front. See Fig. 14. Hook the rear part of the panel on the body, then secure the front with the 2 bolts removed in step 6a.

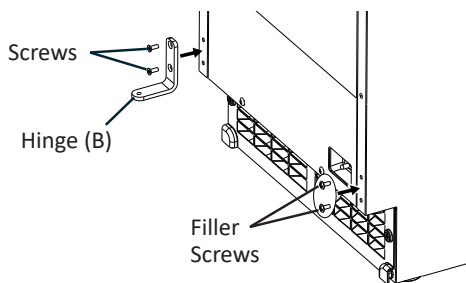

Fig. 13

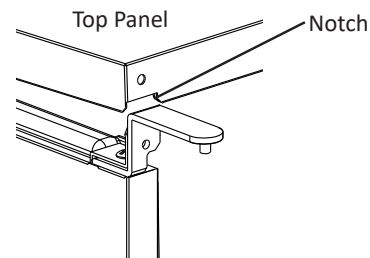

Fig. 14

- f) Remove hinge (C1) from the top right part of the door, flip it and reattach to the bottom left. Remove hinge (C2) from the bottom right part of the door, flip it and reattach to the top left. See Fig. 15. Proceed to step 7.

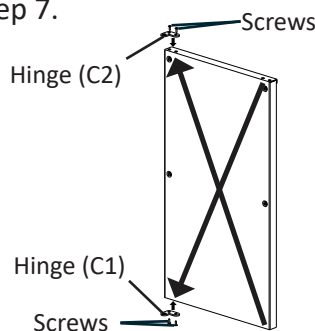

Fig. 15

II. INSTALLATION INSTRUCTIONS

- 7) Remove the bushings from hinge (C1) and hinge (C2) (the hinges attached to the door). See Fig. 16.
- 8) Remove the gasket from the door. See Fig. 17.

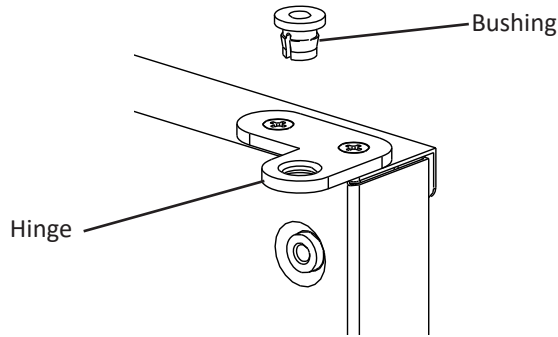

Fig. 16

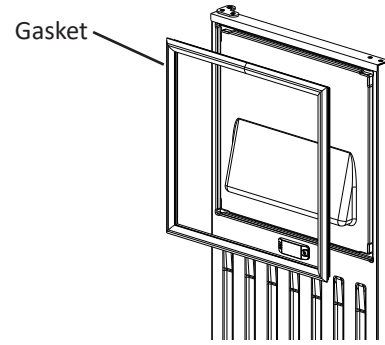

Fig. 17

- 9) Temporarily fasten the overlay panel to the door using 2 of the M4×25 pan head screws provided. **NOTICE! Ensure that the back surface of overlay panel is flat before attaching.** See Fig. 18.
- 10) Mark the center point of the hinge (C1) and hinge (C2) holes that extend over the overlay panel. See Fig. 19.

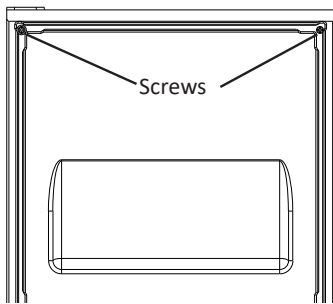

Fig. 18

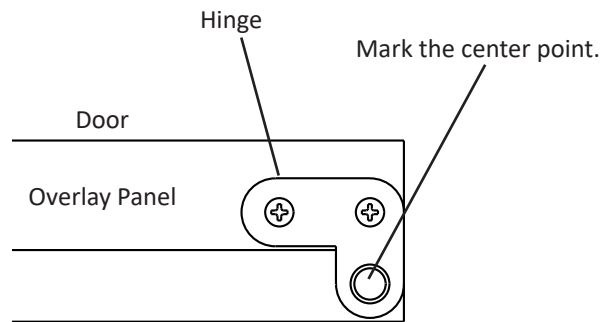

Fig. 19

- 11) Remove the overlay panel from the door.
- 12) Drill 3/8" diameter holes 1/4" (7 mm) deep where you marked on the overlay panel to accommodate the hinge (C1) and hinge (C2) bushings.

II. INSTALLATION INSTRUCTIONS

(4) Attachment of Overlay Panel to Door

- 1) Fasten the sheet metal bracket to the overlay panel using the two M4×8 truss head screws provided. **Snug the screws, but do not tighten.** See Fig. 20.
- 2) Temporarily fasten the overlay panel to the door using 2 of the M4×25 pan head screws provided. See Fig. 21.

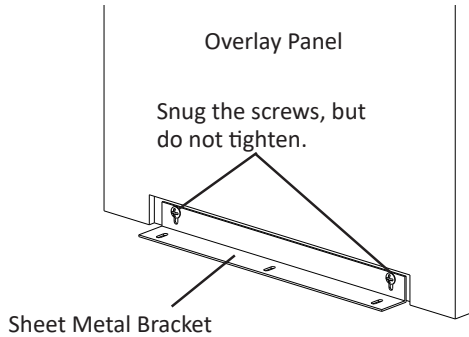

Fig. 20

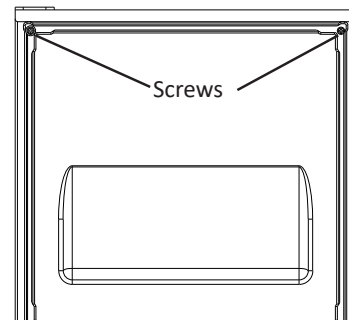

Fig. 21

- 3) Adjust the sheet metal bracket so that it is flush with the bottom of the door. See Fig. 22.
- 4) Remove the overlay panel from the door and tighten the two M4×8 truss head screws securing the sheet metal bracket to the overlay panel. See Fig. 23.

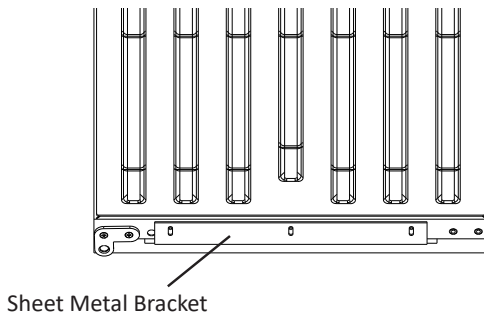

Fig. 22

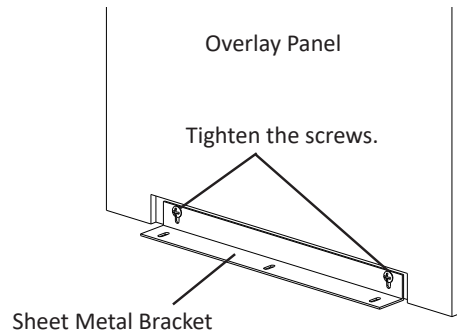

Fig. 23

- 5) Fasten the overlay panel to the door using the four M4×25 pan head screws provided. **Snug the screws, but do not tighten.** See Fig. 24.
- 6) Fasten the sheet metal bracket to the bottom of the door with the three T2 screws provided. Tighten the screws to the door. See Fig. 25.

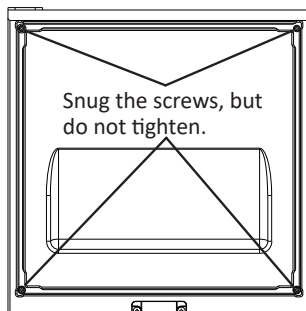

Fig. 24

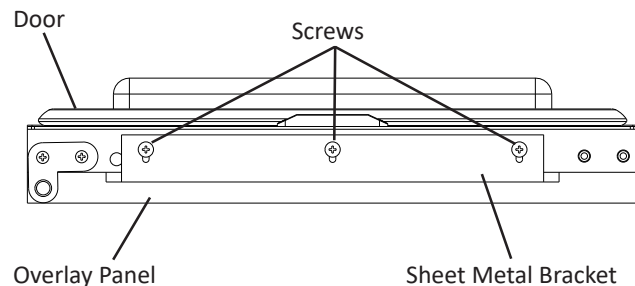

Fig. 25

II. INSTALLATION INSTRUCTIONS

- 7) Tighten the four M4×25 pan head screws installed in step 5. See Fig. 26.
- 8) Replace the door gasket in its proper orientation. Reinsert the bushings into hinge (C1) and hinge (C2) (the hinges attached to the door). See Fig. 27.

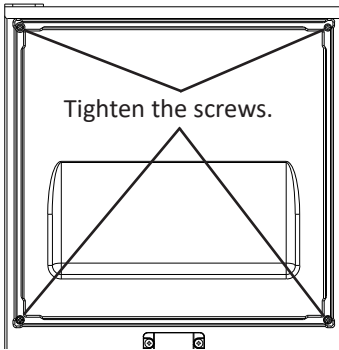

Fig. 26

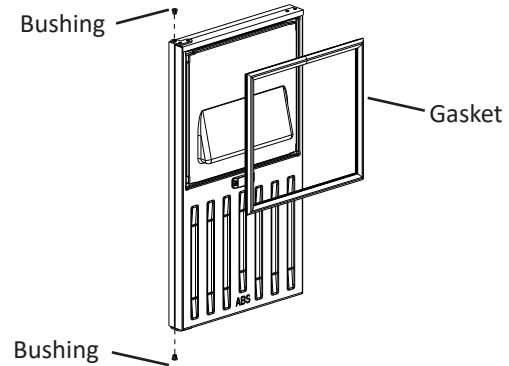

Fig. 27

- 9) Attach the door to hinge (A), then continue to maintain a hold on the door. Screw the hinge stop pin into hinge (B) until it is tight. See Fig. 28.
- 10) Insert the 2 canoe clips included in the accessory bag into the holes on top of the door. See Fig. 29.

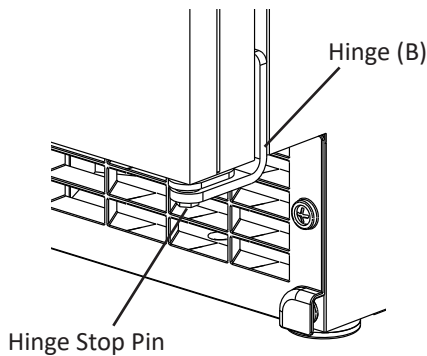

Fig. 28

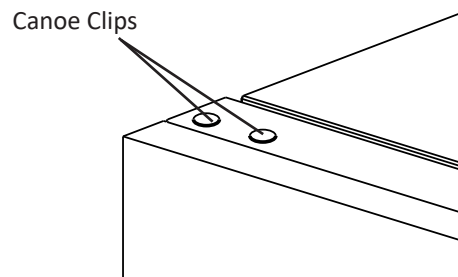
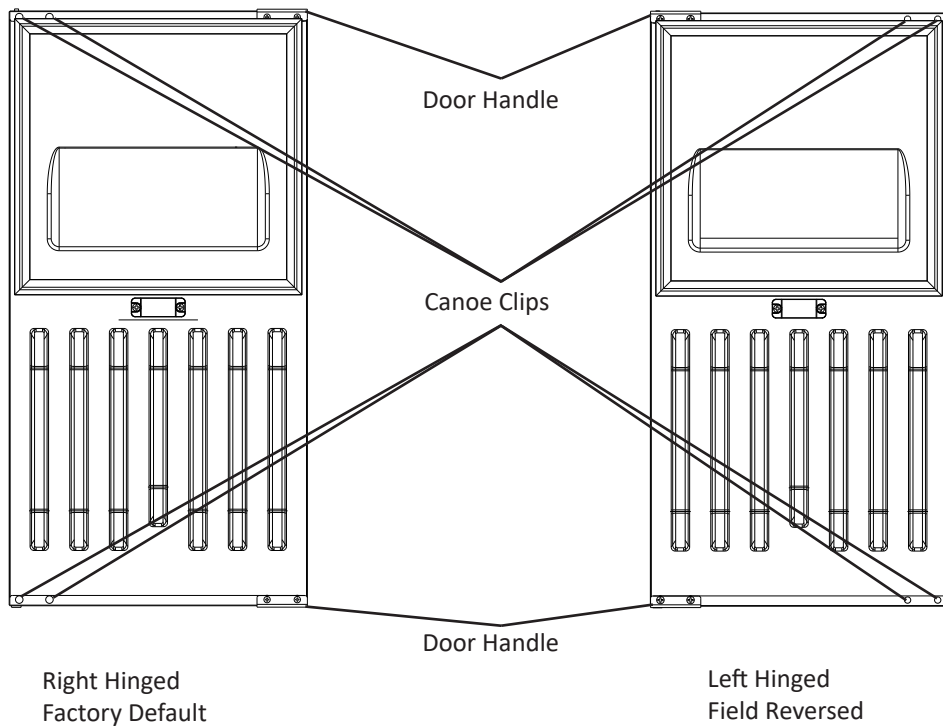

Fig. 29

II. INSTALLATION INSTRUCTIONS**D. Setup**

- 1) Position the appliance in the selected permanent location.
- 2) Level the appliance from side-to-side and front-to-rear by adjusting the feet.
- 3) Insert the 4 canoe clips included in the accessory bag into the upper and lower holes on the inside of the door opposite from the door handle. See Fig. 30.
These holes are provided to allow for door reversal and must be filled when not used.

**Fig. 30**

II. INSTALLATION INSTRUCTIONS

E. Electrical Connection

⚠ WARNING

- Electrical connection must meet national, state, and local electrical code requirements. Failure to meet these code requirements could result in death, electric shock, serious injury, fire, or damage.
 - The appliance requires an independent power supply of proper capacity. See the nameplate for electrical specifications. Failure to use an independent power supply of proper capacity can result in a tripped breaker, blown fuse, damage to existing wiring, or component failure. This could lead to heat generation or fire.
 - **THE APPLIANCE MUST BE GROUNDED:** The appliance is equipped with a NEMA 5-15 three-prong grounding plug  to reduce the risk of potential shock hazards. It must be plugged into a properly grounded, independent 3-prong wall outlet. If the outlet is a 2-prong outlet, it is your personal responsibility to have a qualified electrician replace it with a properly grounded, independent 3-prong wall outlet. Do not remove the ground prong from the power cord and do not use an adapter plug. Failure to properly ground the appliance could result in death or serious injury.
 - Do not use an extension cord.
 - To reduce the risk of electric shock, make sure the control switch is in the "OFF" position before plugging in or unplugging the appliance.
 - To reduce the risk of electric shock, do not touch the control switch or plug with damp hands.
 - Do not use an appliance with a damaged power cord. The power cord should not be altered, jerked, bundled, weighed down, pinched, or tangled. Such actions could result in electric shock or fire. To unplug the appliance, be sure to pull the plug, not the cord, and do not jerk the cord.
 - The GREEN ground wire in the factory-installed power cord is connected to the appliance. If it becomes necessary to remove or replace the power cord, be sure to connect the power cord's ground wire to this screw upon reattachment.
- Usually an electrical permit and services of a licensed electrician are required.
 - The maximum allowable voltage variation is ± 10 percent of the nameplate rating.

II. INSTALLATION INSTRUCTIONS

F. Water Supply and Drain Connections

⚠ WARNING

Water supply and drain connections must be installed in accordance with applicable national, state, and local regulations.

NOTICE

- Normal operating water temperature must be within 45°F to 90°F (7°C to 32°C). Operation of the appliance, for extended periods, outside of this normal temperature range may affect appliance performance.
 - Water supply pressure must be a minimum of 10 PSIG and a maximum of 113 PSIG. If the pressure exceeds 113 PSIG, the use of a pressure reducing valve is required.
 - To prevent damage to the icemaker, do not operate the icemaker when the water supply is off, or if the pressure is below 10 PSIG. Do not run the icemaker until the proper water pressure is reached.
 - External filters, strainers, or softeners may be required depending on water quality. Contact your local Perlick Certified Service Representative or local Perlick distributor for recommendations.
 - Connect to potable water supply only. Do not connect to a hot-water supply.
 - In areas where water damage is a concern, install in a contained area with a floor drain.
 - Water line installation to the appliance is not warranted by Perlick.
 - Water-hammer issues must be resolved by a qualified plumber before installing the appliance. Water hammer can cause appliance damage that may lead to water leakage or flooding.
 - Drain outlet is 1/2" FPT. A 1/2" or 3/4" nominal ID hard pipe or equivalent is required for the drain line. Installing a smaller diameter drain line will reduce water flow and may lead to water leakage or flooding. Installing a larger diameter drain line will reduce water pressure and may lead to water backup in the drain pump activating the overflow safety switch.
 - Test the drain pump, operation every time the icemaker is cleaned and sanitized. See "III.D. Cleaning and Sanitizing" for details. If the drain pump is not operating properly, water could back up and overflow, leading to costly water damage.
-
- A plumbing permit and services of a licensed plumber may be required in some areas.
 - Water supply inlet is 1/2" female pipe thread (FPT).
 - For gravity drain installation, drain must have 1/4" fall per foot (2 cm per 1 m) on horizontal runs to get good flow.

II. INSTALLATION INSTRUCTIONS

Water Supply Inlet	Minimum Water Supply Line Size	Icemaker Drain Outlet	Minimum Drain Line Size
1/2" Female Pipe Thread (FPT)	1/4" Nominal ID Copper Water Tubing or Equivalent	1/2" Female Pipe Thread (FPT)	1/2" Nominal ID Hard Pipe or Equivalent

- A water supply line shut-off valve and drain valve must be installed.
- Be sure there is sufficient extra water supply line and drain line for the appliance to be pulled out for service.

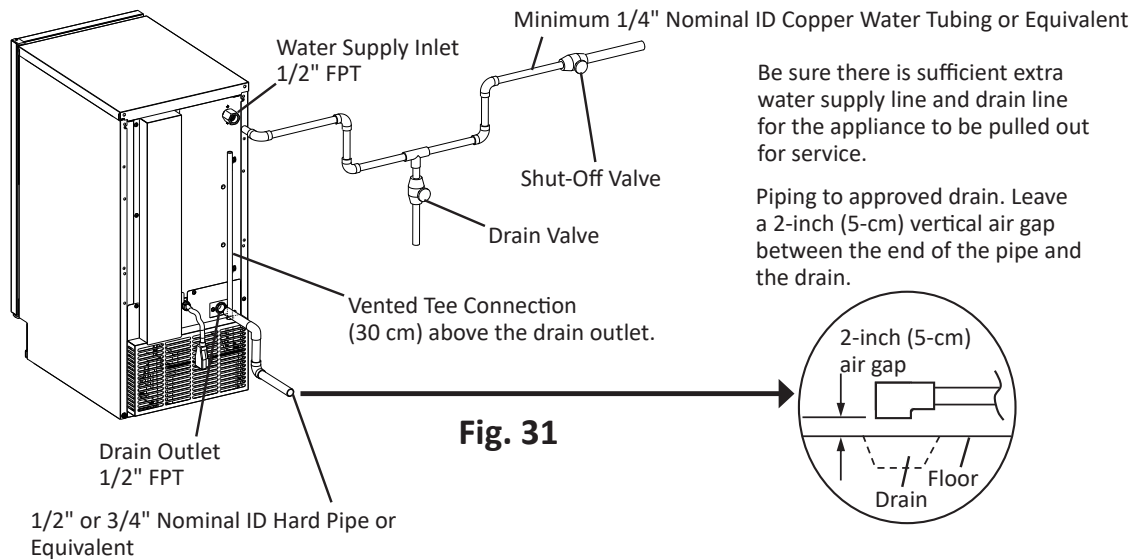

a) **Hard Pipe Drain Line Installation:** When connecting with hard pipe, the maximum hard pipe length is 20 feet (6 m). The maximum discharge hard pipe lift height is 10 feet (3.05 m). See Fig. 32.

b) **Vinyl Hose Drain Line Installation:** When connecting with vinyl tubing, install the vinyl hose barbed fitting from the accessory bag into the drain outlet. Secure the discharge hose to the drain pump with the medium clamp provided in the accessory bag. **NOTICE! Do not over-tighten the clamp.** When routing the vinyl hose, do not allow traps or kinks in the hose that will restrict water flow. The maximum discharge hose length is 20 feet (6 m). The maximum discharge hose lift height is 10 feet (3.05 m). Cut excess hose as needed. See Fig. 32.

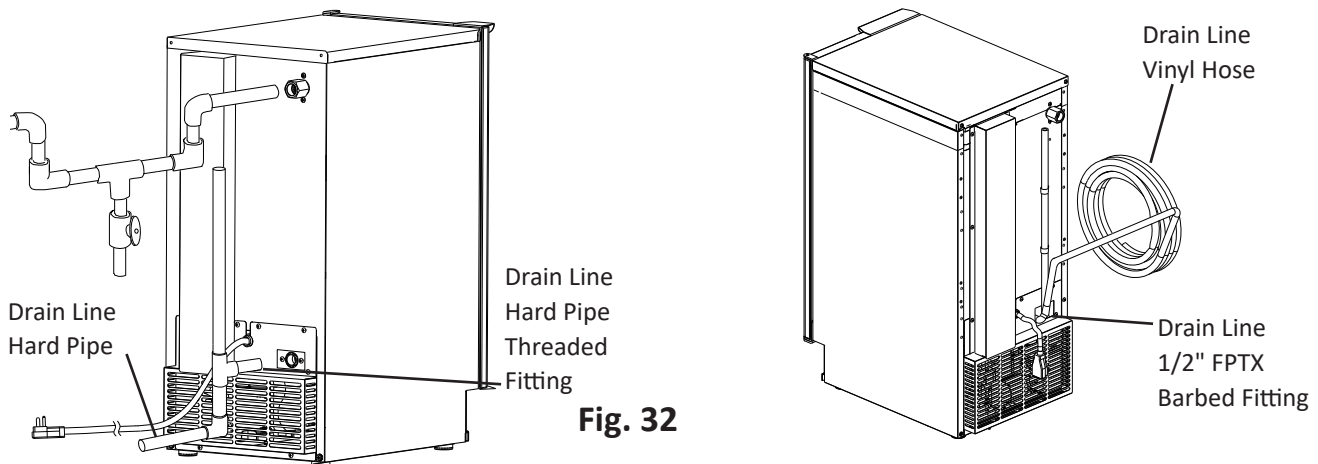

II. INSTALLATION INSTRUCTIONS

- c) **Existing Drain Pipe Installation:** When connecting to a suitable existing drain pipe (sink), the drain line must be installed in accordance with applicable national, state, and local codes and regulations. **IMPORTANT! Confirm with local and state plumbing codes before connecting to an existing drain pipe. An air gap device (not included) may be required. See Fig. 33. NOTICE! Be sure there is sufficient extra tubing for the unit to be pulled out for service.** Do not allow traps or kinks in the hose that will restrict water flow. The maximum discharge hose length is 20 feet (6 m). The maximum discharge hose lift height is 10 feet (3.05 m). Cut excess hose as needed.

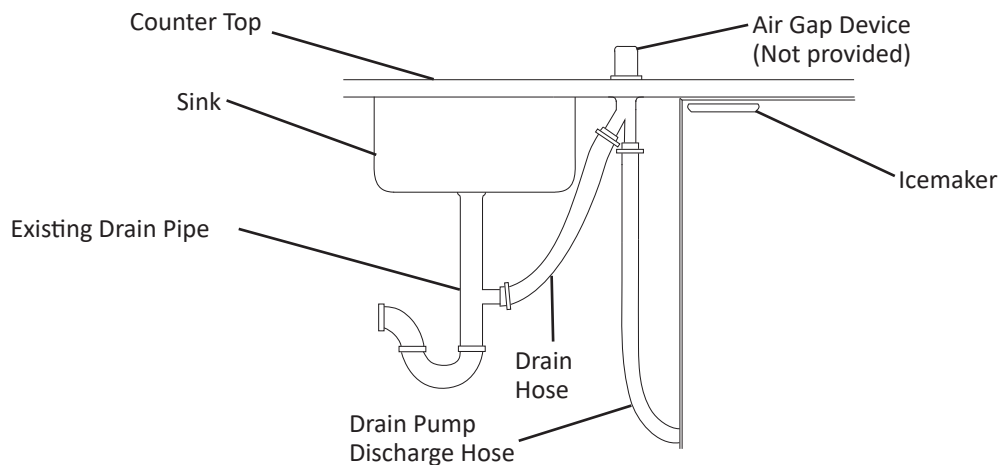
**Fig. 33**

II. INSTALLATION INSTRUCTIONS

G. Final Checklist

⚠ WARNING

CHOKING HAZARD: Ensure all components, fasteners, and thumbscrews are securely in place after installation. Make sure that none have fallen into the storage bin.

1. Pre-Startup

- 1) Is the appliance level?
- 2) Is the toe kick free and clear of obstructions and debris so that air is able to flow freely from the condenser?
- 3) Is the appliance in a site where the ambient temperature is within 45°F to 100°F (7°C to 38°C) and the water temperature within 45°F to 90°F (7°C to 32°C) all year around?
- 4) Have the shipping carton, tape, and packing material been removed from the appliance? Has the protective plastic film been removed from the panels?
- 5) Have all electrical and water connections been made? Do electrical and water connections meet all national, state, and local code and regulation requirements?
- 6) Has the power supply voltage been checked or tested against the nameplate rating? Is the power supply a properly grounded, independent 3-prong wall outlet?
- 7) Are the water supply and drain lines sized as specified? Are the water supply line shut-off valve and drain valve installed? Has the water supply pressure been checked to ensure a minimum of 7 PSIG and a maximum of 113 PSIG?
- 8) Is the compressor snug on all mounting pads? Have the refrigerant lines been checked to make sure they do not rub or touch other lines or surfaces? Has the fan blade (if applicable) been checked to make sure it turns freely?
- 9) Continue to "III.B. Startup".



II. INSTALLATION INSTRUCTIONS

2. Post-Startup

- 1) During the first 5 minutes of the freeze cycle (compressor energized), confirm bin control operation by holding ice in contact with the bin control thermistor. The icemaker shuts down within 30 sec. Remove the ice. After 30 sec. the icemaker restarts the automatic ice making process.
- 2) Slowly pour 24 to 30 oz. (710 to 890 ml) of water over the ice storage bin drain hole in the ice storage bin.
- 3) Confirm that the drain pump water is discharged through the drain line.
- 4) Make sure there are no water leaks.
- 5) Are all components, fasteners, and thumbscrews securely in place?
- 6) Has the end user been given the instruction manual, and instructed on how to operate the appliance and the importance of the recommended periodic maintenance?
- 7) Has the end user been given the contact information of an authorized service agent?
- 8) Has the warranty registration been completed and submitted to the factory?

III. OPERATING INSTRUCTIONS

A. Important Notes About Usage

⚠ WARNING

- Only qualified service technicians should install and service the icemaker.
- Failure to install, operate, and maintain the icemaker in accordance with this manual will adversely affect safety, performance, component life, and warranty coverage.
- To reduce the risk of electric shock, make sure the control switch is in the "OFF" position before plugging in or unplugging the icemaker.
- To reduce the risk of electric shock, do not touch the control switch or plug with damp hands.
- This icemaker must be maintained in accordance with the instruction manual and labels provided with the icemaker. Consult with your local Perlick Certified Service Representative about maintenance service.
- This icemaker must be cleaned and sanitized at least once a year. More frequent cleaning and sanitizing may be required in some water conditions.
- Wash your hands before removing ice. Use the plastic scoop provided.
- This appliance is not intended for use by persons (including children) with reduced physical, sensory, or mental capabilities, or lack of experience and knowledge, unless they have been given supervision or instruction concerning use of the appliance by a person responsible for their safety.
- Children should be properly supervised around this appliance.
- Do not climb, stand, or hang on the icemaker or icemaker door or allow children or animals to do so. Serious injury could occur or the icemaker could be damaged.
- Be careful not to pinch fingers when opening and closing the door. Be careful when opening and closing the door when children are in the area.
- Do not use combustible spray or place volatile or flammable substances near the icemaker. They might catch fire.
- Keep the area around the icemaker clean. Dirt, dust, or insects in the icemaker could cause harm to individuals or damage to the icemaker.

III. OPERATING INSTRUCTIONS**NOTICE**

- Protect the floor when moving the icemaker to prevent damage to the floor.
- Be aware of water left in the discharge pipe or hose in elevated drain line applications.
- To help ensure that the ice storage bin drain remains clear, follow the instructions in "IV.C. Ice Storage Bin Drain" once every 3 months or as often as necessary for conditions. If the ice storage bin drain becomes clogged, water could build up in the bin and overflow, leading to costly water damage.
- Test the drain pump operation every time the icemaker is cleaned and sanitized. See "IV.D. Drain Pump" for details. If the drain pump is not operating properly, water could back up and overflow, leading to costly water damage.
- If water collects in the bin and will not drain, turn off the icemaker and close the water supply line shut-off valve. Call for service.
- Do not leave the icemaker on during extended periods of non-use, extended absences, or in sub-freezing temperatures. To properly prepare the icemaker for these occasions, follow the instructions in "V. Preparing the Icemaker for Periods of Non-Use."
- Keep ventilation openings, in the appliance enclosure or in the built-in structure, clear of obstruction.
- Do not place objects on top of the icemaker.
- The ice storage bin is for ice use only. Do not store anything else in the ice storage bin.

III. OPERATING INSTRUCTIONS

B. Startup

⚠ WARNING

All parts are factory-adjusted. Improper adjustments may adversely affect safety, performance, component life, and warranty coverage.

NOTICE

- If the appliance is turned off, wait for at least 3 minutes before restarting the appliance to prevent damage to the compressor.
- At startup, confirm that all internal and external connections are free of leaks.

- 1) Open the water supply line shut-off valve.
- 2) Make sure the control switch is in the "OFF" position. Plug the appliance into the electrical outlet. **⚠ WARNING** To reduce the risk of electric shock, do not touch the control switch or plug with damp hands. If you have to slide the appliance back for a built-in installation, make sure you do not damage or pinch the water supply line, drain line, or power cord.
- 3) If required by sanitation code in your area, seal the perimeter where the appliance touches the floor with approved caulk compound in a smooth and easily cleanable manner.
- 4) Move the control switch to the "ICE" position to start the automatic icemaking process.
- 5) Once the appliance starts to produce ice, allow it to run for another 30 min.
- 6) At the end of the 30 min. run time, confirm bin control operation, by holding ice in contact with the bin control thermistor. See Fig. 34. The appliance shuts down within 30 sec. Remove the ice. After 30 sec. the appliance restarts the automatic icemaking process.

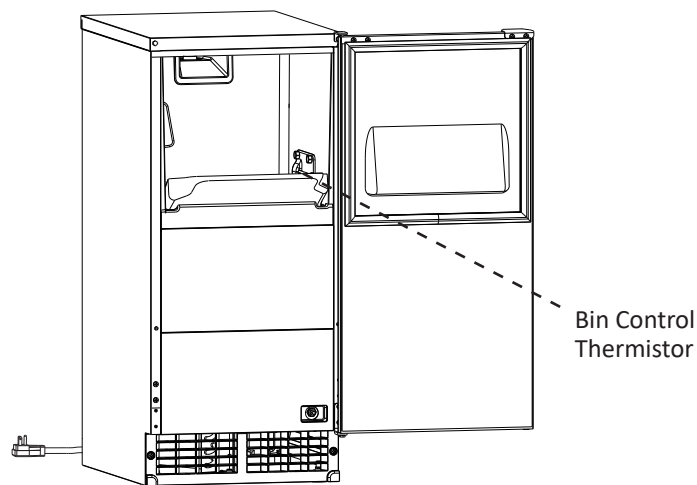

Fig. 34

III. OPERATING INSTRUCTIONS

- 7) Move the control switch to the "OFF" position.
 - ⚠ WARNING** To reduce the risk of electric shock, do not touch the control switch or plug with damp hands.
- 8) Remove the ice produced, then clean the storage bin liner, door liner, and door gasket using a neutral cleaner. Rinse thoroughly after cleaning.
- 9) Plug the icemaker back in.
- 10) Slowly pour 24 to 30 oz. (710 to 890 ml) of water over the ice storage bin drain hole in the ice storage bin.
- 11) If water pumps out properly and the drain pump then de-energizes, proceed to step 12. If water does not pump out properly and/or the drain pump does not de-energize, the appliance must be serviced by a qualified service technician before proceeding.
- 12) Move the control switch to the "ICE" position.
- 13) Check the drain pump back-up safety switch: Pour another 24 to 30 oz. (710 to 890 ml) of water into the icemaker's ice storage bin, then completely restrict/block the appliance hard pipe drain line or the appliance vinyl tubing drain line while the drain pump is operating. See Fig. 35. Pour more water into the icemaker's ice storage bin until the icemaker turns off. The drain pump will continue to operate. Check for leaks.
- 14) Remove the drain line restriction and allow the water to be pumped out normally. Power to the icemaker will be restored when the water in the drain pump returns to a normal level and the back-up safety switch closes.
- 15) Confirm that water is discharged through the discharge hose. The drain pump should then de-energize.
- 16) Make sure there are no water leaks.
- 17) If the icemaker fails to turn off with the drain line restricted or the pump fails to pump out the water, the appliance must be serviced by a qualified service technician.
- 18) Return to "II.G.2. Post Startup."

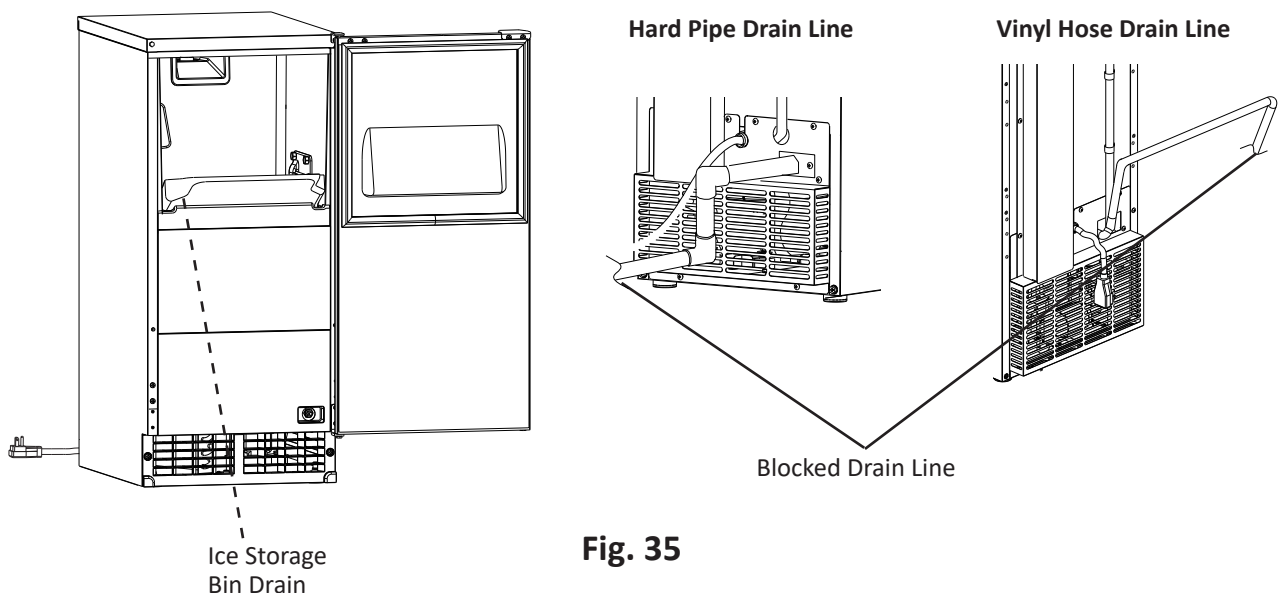

Fig. 35

IV. MAINTENANCE

This icemaker must be maintained in accordance with the instruction manual and labels provided with the icemaker. Consult with your local Perlick Certified Service Representative about maintenance service.

WARNING

- Only qualified service technicians should service the appliance.
- Failure to install, operate, and maintain the equipment in accordance with this manual will adversely affect safety, performance, component life, and warranty coverage.
- To reduce the risk of electric shock, do not touch the control switch or plug with damp hands. Make sure the control switch is in the "OFF" position before plugging in or unplugging the appliance.
- Move the control switch to the "OFF" position and unplug the appliance from the electrical outlet before servicing.
- **CHOKING HAZARD:** Ensure all components, fasteners, and thumbscrews are securely in place after any maintenance is done to the appliance. Make sure that none have fallen into the storage bin.
- Do not place fingers or any other objects into the ice discharge opening.
- After service, make sure that there are no wires pinched between the panels and appliance. Make sure you do not damage or pinch the water supply line, drain line, or power cord.

IV. MAINTENANCE

A. Maintenance Schedule

The maintenance schedule below is a guideline. More frequent maintenance may be required depending on water quality, the appliance's environment, and local sanitation regulations.

Maintenance Schedule		
Frequency	Area	Task
Weekly	Scoop	Clean the scoop using a neutral cleaner. Rinse thoroughly after cleaning.
Monthly	Drain the Appliance	Move the control switch to the "DRAIN" position. Allow the water system to drain for 1 minute. Clear ice away from the thermistor bin control bulb. Move the control switch to the "ICE" position. After the gear motor starts, move the control switch to the "DRAIN" position. Allow the water system to drain for 1 minute. Move the control switch to the "ICE" position to start the automatic icemaking process.
	Appliance Exterior	Wipe down with clean, soft cloth. Use a damp cloth containing a neutral cleaner to wipe off oil or dirt build up. Clean any chlorine staining (rust colored spots) using a non-abrasive cleanser.
Every 3 Months	Storage Bin Drain	Maintain as outlined in "IV.C. Storage Bin Drain."
Every 6 Months	Appliance and Storage Bin	Clean and sanitize per the cleaning and sanitizing instructions provided in this manual. See "IV.B. Cleaning and Sanitizing Instructions."
	Evaporator Condensate Drain Pan and Gear Motor Drain Pan	Wipe down with clean cloth and warm water. <div style="text-align: right; margin-top: 10px;"> </div>
	Drain Pump	Test as outlined in "IV.D. Drain Pump."
	External Water Filters	Check for proper pressure and change if necessary.
	Extruding Head Seal Bolts	Inspect for leakage around seal bolts. Tighten (see torque value below) or replace as necessary. Seal bolts must be replaced once removed because seal material is one-time use only. If new seal bolts do not have pre-applied threadlocker, apply Loctite 243 or equivalent threadlocker to seal bolt threads. <ul style="list-style-type: none"> • Torque: 11.1 ft-lb/15N·m. Tighten 2 times. Allow at least 5 sec. in between each tightening.
Yearly	Water Supply Inlet	Close the water supply line shut-off valve and drain the water system. Clean the water supply inlet screen.
	Condenser	Inspect. Clean if necessary. See "IV.E. Condenser."
	Water Hoses	Inspect the water hoses and clean/replace if necessary.
	Upper Bearing (extruding head)	Check for wear using .02" round stock or pin gauge. Replace both upper bearing and lower bearing if wear exceeds factory recommendations. See the Service Manual for details.
After 3 Years, then Yearly	Upper Bearing (extruding head); Lower Bearing and O-Ring (lower housing); Mechanical Seal; Evaporator Cylinder; Auger	Inspect. Replace both upper bearing and lower bearing if wear exceeds factory recommendations. Replace the mechanical seal if the seal's contact surfaces are worn, cracked, or scratched.

IV. MAINTENANCE

B. Cleaning and Sanitizing Instructions

The appliance must be cleaned and sanitized at least twice a year. More frequent cleaning and sanitizing may be required in some conditions.

⚠ WARNING

- To prevent injury to individuals and damage to the appliance, do not use ammonia type cleaners.
- Carefully follow any instructions provided with the cleaning and sanitizing solutions.
- Always wear liquid-proof gloves and goggles to prevent the cleaning and sanitizing solutions from coming into contact with skin or eyes.
- Do not use ice made from the cleaning and sanitizing solutions. After cleaning and sanitizing, be careful not to leave any solution in the appliance.
- Do not place fingers or any other objects into the ice discharge opening (extruding head).

1. Cleaning Solution

Mix a minimum of 1 gallon of warm water, with an ice machine cleaner or descaler of your choice. See Ice Machine cleaner instruction for proper dilution amount by brand. Make more solution if necessary. **IMPORTANT! For safety and maximum effectiveness, use the solution immediately after dilution.**

2. Cleaning Procedure

- 1) Move the control switch to the "OFF" position.
- 2) Remove all ice from the storage bin.
- 3) Move the control switch to the "DRAIN" position.
- 4) Allow the water system to drain for 1 minute.
- 5) Move the control switch to the "OFF" position.
- 6) Using a clean funnel and hose (not included), pour 1 qt (1 l) of cleaning solution over the extruding head. See Fig. 36. Allow the appliance to sit for 10 minutes before operation.

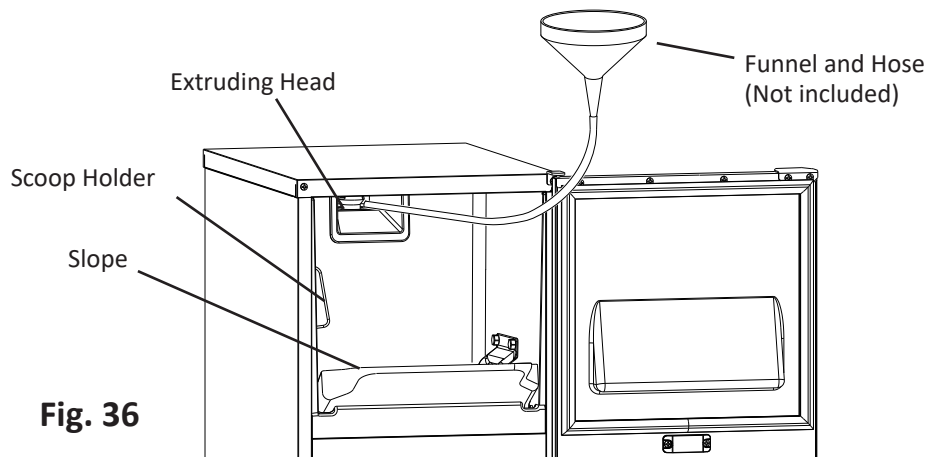

IV. MAINTENANCE

- 7) Make sure at least 10 minutes have elapsed since you poured the cleaning solution over the extruding head, then move the control switch to the "ICE" position.
- 8) Allow the appliance to make ice for 20 minutes, then move the control switch to the "DRAIN" position.
- 9) Allow the water system to drain for 1 minute.
- 10) Move the control switch to the "ICE" position.
- 11) After the gear motor starts, move the control switch to the "DRAIN" position.
- 12) Allow the water system to drain for 1 minute.
- 13) Move the control switch to the "OFF" position. In severe water conditions, repeat the cleaning procedure.

Note: If you do not sanitize the appliance, go to step 8 in "IV.B.5. Sanitizing Procedure - Final."

3. Sanitizing Solution

Dilute 0.85 fl. oz. (25.14 ml or 1.7 tbs) of a 7.5% sodium hypochlorite solution (chlorine bleach) with 2.5 gallons (9.5 l) of warm water. This is a minimum amount. Make more solution if necessary. Using a chlorine test strip or other method, confirm that you have a concentration of about 200 ppm.

IMPORTANT! For safety and maximum effectiveness, use the solution immediately after dilution.

4. Sanitizing Procedure - Initial

- 1) Using a clean funnel and hose, pour 1 qt (1 l) of sanitizing solution over the extruding head. Allow the appliance to sit for 10 minutes before operation.
- 2) Remove the slope from the storage bin by carefully bending it in the center and releasing it from the 2 slope shafts.
- 3) Remove the scoop. Remove the 2 thumbscrews securing the scoop holder, then remove it.
- 4) Pour some of the sanitizing solution into a separate, clean container. Using this sanitizing solution and a clean cloth, wipe down the slope, scoop, scoop holder, inside of the spout, and bin liner.
- 5) Rinse the parts and areas sanitized in step 4 thoroughly with clean water.
- 6) Replace all removed parts in their original and correct positions.
⚠ WARNING CHOKING HAZARD: Ensure all components, fasteners, and thumbscrews are securely in place. Make sure that none have fallen into the storage bin.
- 7) Make sure at least 10 minutes have elapsed since you poured the sanitizing solution over the extruding head, then move the control switch to the "ICE" position.
- 8) Allow the appliance to make ice for 20 minutes, then move the control switch to the "DRAIN" position.
- 9) Allow the water system to drain for 1 minute.
- 10) Move the control switch to the "ICE" position.
- 11) After the gear motor starts, move the control switch to the "DRAIN" position.
- 12) Allow the water system to drain for 1 minute.
- 13) Move the control switch to the "OFF" position.

IV. MAINTENANCE

5. Sanitizing Procedure - Final

- 1) Using a clean funnel and hose, pour 1 qt (1 l) of sanitizing solution over the extruding head. Allow the appliance to sit for 10 minutes before operation.
- 2) Move the control switch to the "ICE" position.
- 3) Allow the appliance to make ice for 20 minutes, then move the control switch to the "DRAIN" position.
- 4) Allow the water system to drain for 1 minute.
- 5) Move the control switch to the "ICE" position.
- 6) After the gear motor starts, move the control switch to the "DRAIN" position.
- 7) Allow the water system to drain for 1 minute.
- 8) Move the control switch to the "ICE" position and allow the appliance to run. Check for leaks.
- 9) After 30 minutes, move the control switch to the "OFF" position.
- 10) Pour warm water into the storage bin to melt all of the ice, then clean the storage bin liner, door liner, and door gasket with a neutral cleaner. Rinse thoroughly after cleaning.
- 11) Move the control switch to the "ICE" position to start the automatic icemaking process.

C. Storage Bin Drain

In some conditions, slime may build up inside the storage bin drain and prevent water from draining properly. To prevent this buildup, perform the following procedure once every 3 months or as often as necessary for conditions.

NOTICE

If the storage bin drain becomes clogged, water could build up in the bin and overflow, leading to costly water damage.

- 1) Move the control switch to the "OFF" position.
⚠ WARNING To reduce the risk of electric shock, do not touch the control switch with damp hands.
- 2) Remove all ice from the storage bin.
- 3) Mix a batch of sanitizing solution by diluting 0.85 fl. oz. (25.14 ml or 1.7 tbs) of a 7.5% sodium hypochlorite solution (chlorine bleach) with 2.5 gallons (9.5 l) of warm water. Using a chlorine test strip or other method, confirm that you have a concentration of about 200 ppm.
IMPORTANT! For safety and maximum effectiveness, use the solution immediately after dilution.
- 4) Slowly pour the sanitizing solution into the storage bin.
- 5) After all of the solution has drained, clean the storage bin liner with a neutral cleaner. Rinse thoroughly with clean water.
- 6) Move the control switch to the "ICE" position to start the automatic icemaking process.

IV. MAINTENANCE

D. Drain Pump

NOTICE

Be aware of water left in the discharge pipe or hose in elevated drain line applications.

- 1) To test the operation of the drain pump and internal safety switch, move the control switch to the "ICE" position or the power switch to the "ON" position (dependent on model).
- 2) Pour 24 to 30 oz. (710 to 890 ml) of water into the icemaker's ice storage bin, then completely restrict the discharge hose while the drain pump is operating. Pour more water into the icemaker's ice storage bin until the icemaker turns off. The drain pump will continue to operate.
- 3) Check for leaks. Remove the discharge hose restriction and allow the water to be pumped out normally. The power to the icemaker will be restored when the water in the drain pump returns to a normal level.

E. Condenser

Check the condenser once a year, and clean if required by following the steps below. More frequent cleaning may be required depending on location.

WARNING

Condenser fins are sharp. Use care when cleaning.

- 1) Move the control switch to the "OFF" position, then unplug the appliance from the electrical outlet. **WARNING** To reduce the risk of electric shock, do not touch the control switch or plug with damp hands.
- 2) Remove the screws securing the front panel, then remove it. See Fig. 37.
- 3) Remove the screws securing the louver, then remove it.
- 4) Use a brush attachment on a vacuum cleaner to gently clean the condenser fins. Do not use too much force, otherwise the fins could be damaged.
- 5) Replace the louver and front panel in their correct positions. Ensure that the screws are securely in place.
- 6) Plug the appliance back in. Move the control switch to the "ICE" position to start the automatic icemaking process.

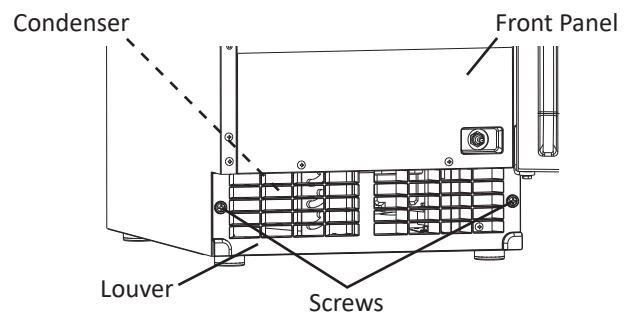

Fig. 37

V. PREPARING THE APPLIANCE FOR PERIODS OF NON-USE

During extended periods of non-use, extended absences, or in sub-freezing temperatures, follow the instructions below. When the appliance is not used for two or three days under normal conditions, it is sufficient to move the control switch to the "OFF" position.

⚠ WARNING

Only qualified service technicians should service the appliance.

NOTICE

During extended periods of non-use, extended absences, or in sub-freezing temperatures, follow the instructions below to reduce the risk of costly water damage.

- 1) Move the control switch to the "OFF" position.
⚠ WARNING To reduce the risk of electric shock, do not touch the control switch or plug with damp hands.
- 2) Close the water supply line shut-off valve, then open the water supply line drain valve. See Fig. 31.
- 3) Allow the line to drain by gravity.
- 4) Move the control switch to the "DRAIN" position.
- 5) Allow the water system to drain for 1 minute.
- 6) Attach a compressed air or carbon dioxide supply to the water supply line drain valve.
- 7) Move the control switch to the "ICE" position.
- 8) Blow the water supply line out using the compressed air or carbon dioxide supply.
- 9) Close the water supply line drain valve.
- 10) Move the control switch to the "OFF" position, then unplug the appliance from the electrical outlet.
- 11) Remove the screws securing the upper rear panel, then remove it. See Fig. 38.
- 12) Remove the clamp securing the reservoir outlet hose to the reservoir. Disconnect the reservoir outlet hose from the reservoir.
- 13) Attach a compressed air or carbon dioxide supply to the reservoir outlet hose.

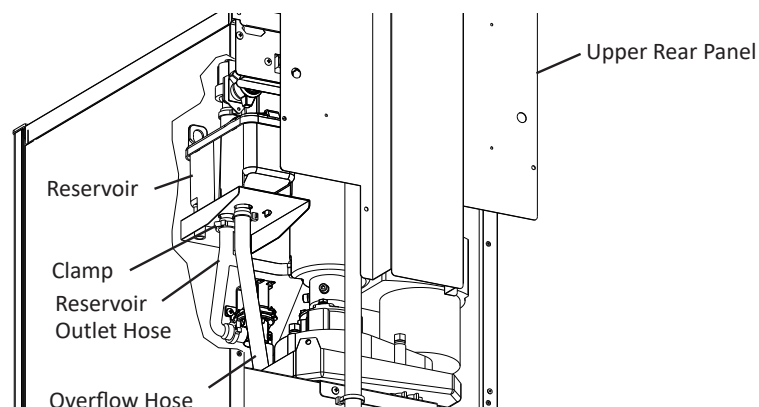
Fig. 38



V. PREPARING THE APPLIANCE FOR PERIODS OF NON-USE

- 14) Plug the appliance back in, then move the control switch to the "DRAIN" position.
- 15) Blow out the reservoir outlet hose using the compressed air or carbon dioxide supply.
- 16) Move the control switch to the "OFF" position, then unplug the appliance from the electrical outlet.
- 17) Reconnect the reservoir outlet hose to the reservoir, then secure with the clamp. Make sure all hoses are connected and secure.
- 18) Replace the rear panel in its correct position.
- 19) Clean the storage bin by using a neutral cleaner. Rinse thoroughly after cleaning.

VI. DISPOSAL

This icemaker contains refrigerant and must be disposed of in accordance with applicable national, state, and local codes and regulations. Refrigerant must be recovered by properly certified service personnel.



© 2024 Perlick Corporation

8300 West Good Hope Road, Milwaukee, WI 53223, USA
perlick.com/residential • (800) 558-5592

Form No. Z2547
Rev. 07.03.24

1A7613-010